



Magellan NAV 6000 User Manual

© 1998 by Magellan Systems Corporation. All rights reserved.

No part of this User Guide may be reproduced or transmitted in any form or by any means, electronic or mechanical, including photocopying and recording, for any purpose other than the purchaser's personal use without the written permission of Magellan Systems Corporation.

Magellan™, GPS NAV 6000™ are the trademarks of Magellan Systems Corporation.

Part No. 22-10311-001

Magellan Systems Corporation

Limited Warranty

All Magellan GPS receivers are navigational aids, and are not intended to replace other methods of navigation. Purchaser is advised to perform careful position charting and use good judgement. **Read the User Guide carefully before using this product.**

1. MAGELLAN SYSTEMS CORPORATION WARRANTY

Magellan Systems Corporation warrants their GPS receiver and accessories to be free of defects in material and workmanship for a period of one year from the date of original purchase. **This warranty applies only to the original purchaser of this product.**

In the event of a defect, Magellan Systems Corporation will, at its option, repair or replace the product with no charge to the purchaser for parts or labor. The repaired or replaced product will be warranted for ninety (90) days from the date of return shipment, or for the balance of the original warranty, whichever is longer.

2. PURCHASER'S REMEDY

Purchaser's Exclusive Remedy under this written warranty or any implied warranty shall be limited to the repair or replacement, at Magellan Systems Corporation's option, of any defective part of the receiver or accessories which are covered by this warranty. Repairs under this warranty shall only be made at an authorized Magellan Service Center.

3. PURCHASER'S DUTIES

To obtain warranty service, the purchaser must return the receiver or accessories postpaid, with proof of the date of original purchase and purchaser's return address to **Magellan Authorized Service Centers.**

Magellan Systems Corporation will not be responsible for any losses or damage to the product incurred while the product is in transit or is being shipped for repair. Insurance is recommended.

4. LIMITATION OF IMPLIED WARRANTIES

Except as set forth in item 1 above, all other expressed or implied warranties, including those of fitness for any particular purpose and merchantability, are hereby disclaimed.

Some states do not allow limitations on warranties, so the above limitation may not apply to you.

5. EXCLUSIONS

This warranty does not cover the following:

- Installation
- Batteries
- Finishes
- Defects resulting from installation
- Any damage due to accident, resulting from inaccurate satellite transmissions. Inaccurate transmissions can occur due to changes in the position, health, or geometry of a satellite.
- Any damage due to shipping, misuse, negligence or tampering, or improper use.
- Servicing performed or attempted by anyone other than an authorized Magellan Service Center representative.

- Modifications to the receiver which may be required due to any change in the Global Positioning System (GPS). [Note: All Magellan GPS receivers use GPS to obtain position, velocity, and time information. GPS is operated by the U.S. Government, which is solely responsible for its accuracy and maintenance. Certain conditions can cause inaccuracies which could require modifications to the receiver. Examples of such conditions include but are not limited to changes in the GPS transmission. Such modifications are **not** covered by this warranty.]

Opening of this product by anyone other than an Authorized Magellan Service Center representative will void this warranty.

6. EXCLUSION OF INCIDENTAL OR CONSEQUENTIAL DAMAGES

Magellan Systems Corporation shall not be liable to purchaser or any other person for any incidental, special, indirect, or consequential damages whatsoever, including but not limited to lost profits, damages resulting from delay or loss of use, loss of or damages arising out of the use or inability to use this product, or breach of this warranty even though caused by negligence or other fault. In no event will Magellan Systems Corporation be responsible for such damages, even if Magellan Systems Corporation has been advised of the possibility of such damages.

Some states do not allow the exclusion or limitation of incidental or consequential damages, so the above limitation or exclusion may not apply to you.

7. MERGER

This written warranty is the complete, final, and exclusive agreement between Magellan Systems Corporation and the purchaser with respect to the quality of performance of all the goods and any and all warranties and representations. **This warranty sets forth all of Magellan Systems Corporation's responsibilities regarding this product.**

This warranty gives you specific legal rights and you may also have other rights which vary from state to state.

8. FOR PURCHASERS OUTSIDE OF THE UNITED STATES

This warranty gives you specific rights. You may have other rights which vary from province to province and certain limitations contained in this limited warranty may not apply to you.

If you purchased this product outside of the United States, this limited warranty is governed by the laws of the State of California and shall benefit Magellan Systems Corporation, its successors, and assigns.

For further information concerning this limited warranty, please call or write:

Magellan Systems Corporation
960 Overland Court
San Dimas, California, 91773
Phone: (909) 394-5000 FAX: (909) 394-7050



Magellan NAV 6000 User Manual

WARNINGS

USE GOOD JUDGEMENT

This product is an excellent navigation aid, but does not replace the need for careful orienteering and good judgement. Never rely solely on one device for navigating.

USE CARE

The Global Positioning System (GPS) is operated by the U.S. Government, which is solely responsible for its accuracy and maintenance.

The accuracy of position fixes can be affected by the periodic adjustments to GPS satellites made by the U.S. Government and is subject to change in accordance with the Department of Defense civil GPS user policy and the Federal Radionavigation Plan.

USE CAUTION

Accuracy can be affected by poor satellite geometry. When accuracy warnings appear on the screen, use the data with extreme caution.

USE PROPER ACCESSORIES

Use only Magellan cables and antennas; the use of non-Magellan cables and antennas may severely degrade performance or damage the receiver, and will void the warranty.

LICENSE AGREEMENT

Magellan grants you, the purchaser, the right to use the software supplied in and with MAGELLAN GPS products (the "SOFTWARE") in the normal operation of the equipment. You may make copies only for your own personal use and for use within your organization.

The SOFTWARE is the property of MAGELLAN and/or its suppliers and is protected by United States copyright laws and international treaty provisions; therefore, you must treat this SOFTWARE like any other copyright material.

You may not use, copy, modify, reverse engineer or transfer this SOFTWARE except as expressly provided in this license. All rights not expressly granted are reserved by MAGELLAN and/or its suppliers.

* * *

Contents

Introduction	1		
Packing List	1	Map Screen	19
Conventions Used in this Manual	2	Setting the Map Scale	20
Commonly Used Terms	2	Using the Cursor Key on the Map Screen	21
Getting Started	3	Map Orientation	21
Magellan NAV 6000 Description	3	Plotter Mode	22
Language Selection	4	Viewing Waypoint and Navaid Attributes	23
Power ON/OFF	5	Finding Distance and Bearing from a Point on the Map	25
Adjusting Contrast	6	NAV 1 Screen	25
Adjusting Backlighting	6	Customizing the Nav 1 Screen	26
First Time Use - Initializing the Receiver	6	NAV 2 Screen	26
Tutorial	9	Customizing the Nav 2 Screen	26
Reference	15	Pointer Screen	27
General Usage	15	Waypoints	28
Turning the Receiver ON/OFF	15	Creating a Waypoint	28
Cancelling an Operation	16	Saving the Cursor Position as a Waypoint	28
Inputting Data	16	Saving the Current Position Fix as a Waypoint	29
Adjusting Contrast	16	Modifying Waypoint Data Fields	29
Adjusting Backlighting	16	Finding a Waypoint in the Waypoint List	30
Root Screens	16	Viewing a Waypoint from the Waypoint List	30
Satellite Status Screen	17	Editing a Waypoint from the Waypoint List	31

Deleting Waypoints from the Waypoint List	31	Moving a Waypoint in a Route	41
Listing the Nearest Waypoints	32	Replacing a Waypoint in a Route Manually	42
Moving a Waypoint	32	Activating a Leg of a Route	42
Routes	33	Deleting a Route on the Map	43
Creating a GOTO Route Using the Waypoint List	33	Deleting a Route in the List	43
Creating a GOTO Route Using the Nearest List	34	Copying a Route	43
Creating a GOTO Route using the Find Function	34	Creating a Backtrack Route	44
Creating a GOTO Route to the Cursor Position	35	Activating a Backtrack Route	44
Creating a MOB Route	35	Deactivating a Backtrack Route	44
Deleting a GOTO Route	35	Menu Functions	45
Multi-Leg Routes	36	System Setup	45
Creating a Multi-Leg Route Using the Map	36	Adjusting Contrast	45
Creating a Multi-Leg Route Manually	36	Setting Time Format	45
Activating a Route	37	Setting Date Format	46
Deactivating a Route	37	Selecting Coordinate System	46
Reversing a Route from the List	38	Selecting Map Datum	47
Editing a Route	38	Selecting Elevation Mode	47
Inserting a Waypoint in a Route on the Map	38	Selecting Elevation, Distance, Speed and	
Inserting a Waypoint in a Route Manually	39	Depth Units	47
Removing a Waypoint from a Route	40	Elevation Units	47
Appending a Waypoint to the End of		Distance Units	48
a Route on the Map	40	Speed Units	48
Appending a Waypoint to the End of		Depth Units	48
a Route Manually	41	Selecting North Reference	48

Port Setup Functions	49	Simulation Mode Function	58
Setting NMEA Output	49	Memory Reset	58
Setting NMEA Baud Rate	49	Troubleshooting	60
Turning the Beeper On or Off	50	Warnings/Alarms	62
Activating Alarms	50	NAV 6000 Appendix	63
Setting Arrival Radius	50	Installation Instructions	64
Setting Anchor Alarm	50	Battery Installation	64
Setting XTE Alarm	51	C-Card Installation	65
Map Setup	51	Nav 6000 Swivel Mounting Bracket (Optional)	67
Map Configuration Functions	51	Electrical Connections	69
Turning Land Settings On and Off	51	Connecting the DC Power/NMEA Data Cable	69
Turning Marine Settings On and Off	52	Connecting the PC Cable (Optional)	70
Turning Nav-Aid Settings On and Off	52	Proper External Antenna Installation -	
Turning Chart Settings On and Off	53	Signal Reception	71
Selecting Map Orientation	53	Navaid Icons	72
Projected Course Indicator	54	List of Available Datums	77
Map Shift	54	NMEA Messages	78
Track History Functions	55	Abbreviations	84
Turning Track History On or Off	56	Specifications	86
Choosing the Distance Resolution	56	Coordinate Systems	87
Clearing Track Memory	56	What Is GPS?	89
Trip Planning Function	56	Explanation of Data Terms	91
Calculating Sunrise/Sunset		Glossary	93
and Lunar Information	57	Index	96

Introduction



Congratulations on your purchase of the Magellan NAV 6000. The NAV 6000 integrates the remarkable accuracy of a GPS receiver with a broad range of electronic chart and navigation aids into a single easy-to-use navigation information center.

The NAV 6000 uses C-MAP *NT* marine cartography and can store up to 500 waypoints, and 25 routes with up to 30 legs. The large LCD display features a help bar on every screen and can be used either with cartography or as a track plotter to monitor progress.

This manual is divided into five chapters; *Introduction*, *Getting Started*, *Tutorial*, *Reference*, and *Appendix*. It is very important that you go through the *Getting Started* chapter first as it prepares your receiver for use and provides basic instruction for getting you up and running with your GPS receiver.

The fourth chapter is a *Reference Section* for the features found in your receiver including step-by-step instructions on their use. Because of the advanced navigational features of the receiver, some of the terminology used in these procedures may be new to you. As you use the receiver such terms as waypoints, leg, route, etc. will quickly become familiar.

The final chapter of this manual, *Appendix*, contains some further explanations and information that will help you use your receiver and defines many of the terms that may be unfamiliar.

Packing List

The following items should be in your package:

- NAV 6000 receiver
- Quick Reference Card
- User Guide
- Carrying Case
- Warranty registration card
- C-Map Documentation/Ordering Information
- Batteries

If any of these items is missing, please contact your local Magellan dealer or distributor.

Conventions Used in this Manual

The Reference section of this manual is designed to assist you in the use of your Magellan NAV 6000. Each topic in the Reference section includes a brief description of the activity chosen, a pictorial view of the keys to press, and a detailed description with sample screens of how to perform the activity. As you become more familiar with your receiver, you will be able to use the pictorial view of the keys as a "quick reference" to perform the desired activity.

Also in the Reference section are alerts to inform you of some cautions or notes that will assist you in using your NAV 6000.



The stop sign indicates information that is very important and should be read before continuing.



The Magellan logo denotes information that can help you use or understand your receiver. While this information is not required to perform the activity, it may provide you with a better understanding of the activity or shortcuts you can use.

Commonly Used Terms

A few of the terms used in this manual may be unfamiliar to you and are described in the *Glossary* found in the Appendix. To help you get started, some of the more common terms are described here with a simple explanation as to their meaning.

Position Fix: The NAV 6000 receives information from GPS satellites to compute a value (coordinates) that describes your unique position on the earth. This is called taking a position fix and the coordinates computed are referred to as the position fix.

Waypoint: (Abbreviated as WPT.) A position fix or any other position can be saved in memory with a name and type that you either assign or let the NAV 6000 assign for you. These saved positions are called waypoints.

MARK: You can mark the cursor position or your present position at any time by pressing the MARK key to create a waypoint.

GOTO: You can actually "Go To" a saved waypoint or any cursor position simply by pressing the GOTO key and choosing a destination waypoint. The NAV 6000 will navigate you from your present position to the waypoint chosen with bearing and distance information.

Route: A route is slightly different from a GOTO. A route contains a starting and ending waypoint and may include intermediate waypoints along the way. Routes can be from one waypoint to another (a single-leg route) or from a waypoint to a series of waypoints, (a multi-leg route) up to 30 legs.

Leg: Legs are the divisions of a route between waypoints. A route that goes from WPT A to WPT B, from WPT B to WPT C, and from WPT C to WPT D has three legs.

Getting Started



This section shows you how to begin using your MAGELLAN NAV 6000 for the first time. After a brief description of the receiver, it discusses:

- Turning power on and off
- Adjusting contrast and backlighting
- First time use, initializing the receiver
- Navigating

Magellan NAV 6000 Description

The Magellan GPS NAV 6000 has a high contrast, high resolution backlit LCD, and backlit keypad and is designed to be used as a hand-held or bracket-mounted.

The NAV 6000 is powered by 6AA batteries and has a built-in antenna. A connector on the back of the unit allows you to attach an external antenna (not included). The Power/Data Cable (not included) can be connected to the 5-pin connector on the back of the unit for external power input and data input/output.

Mount the unit as you plan to use it, and make all the electrical and data connections before you attempt to operate it. See the *Installation* section in the Appendix for details on mounting and connecting the NAV 6000.

Keys

ZOOM IN - Changes the displayed map scale to view a smaller area in greater detail.

ZOOM OUT - Changes the displayed map scale to view a larger area in less detail.

CURSOR KEY - Controls cursor movement, and is used to select menu items as well as scroll through the alphanumeric series for data entry. The UP/DOWN and RIGHT/LEFT indicators on the CURSOR KEY move the cursor or highlight in the cardinal directions, up, down, right and left. The dots on the cursor key move the cursor diagonally on the map display.

ENTER - Used to confirm data entry and confirm selections on the screen.

MAP/CTR - Centers the boat or cursor on the screen and allows toggling between the boat and the cursor position. Used to display the Map screen from any screen and centers the map on the last computed position.

GOTO - Creates a one-leg route directly to the selected waypoint or to the cursor position.

MARK - Records the present boat position or cursor position (if the map is displayed), as a stored waypoint.

QUIT - Cancels and backs out of an operation or backs up one step in a sequence. Allows stepping through root screens in reverse order.

POWER - Turns the NAV 6000 on and off and adjusts the LCD and keys' backlight intensity.

SOFTKEYS - Softkey functions are accessed using the keys along the bottom of the display. Softkey functions appear at the bottom of each screen.

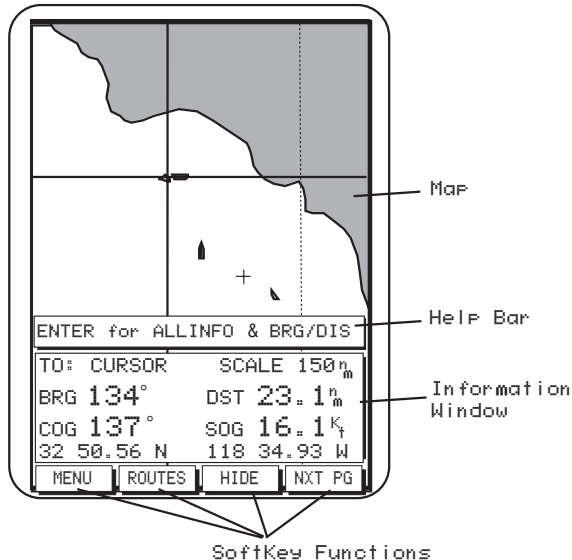

When the text of the softkey function is dark, the feature is accessible; when the text is grayed out, the function is available from this screen but is not currently accessible.

Using the Help Bar. The map screen and many of the function screens contain a help bar, located just above the NAV window, which tells you which action or actions you may perform on the current screen.

Language Selection

The NAV 6000 allows you to view the screens in five different languages. You can choose from Spanish, German, French, Italian and English.

Once the NAV 6000 has been powered on, a navigation warning screen will appear. To make your selection, press one of the softkeys labeled with the language you would like or press ENTER to continue in English.

Magellan NAV 6000 GPS Receiver



Power ON/OFF

To turn power on :

Press the **POWER** key until the “MAGELLAN NAV 6000” screen is displayed (approximately 5 seconds).

From the navigation warning screen, press one of the softkeys for a different language or press **ENTER** to continue.

To turn power off :

Press and hold down the **POWER** key.

The receiver will begin a countdown sequence that will last for 5 seconds. The window will countdown from 4 to zero.

Pressing any key except **POWER** will stop the receiver from turning off. Pressing **POWER** after countdown starts will eliminate the countdown and turn off the unit immediately.

Adjusting Contrast

Press the MENU softkey to access the *FUNCTION MENU* screen.

Highlight *System Setup* and press ENTER to access the Setup Menu, containing the Contrast option.

With Contrast highlighted, press ENTER. A bar graph appears.

Use the RIGHT/LEFT arrows on the CURSOR KEY to adjust the contrast to a comfortable level, then press ENTER to confirm.

Press QUIT twice to back out of the Setup and Function Menu screens.

Adjusting Backlighting

Adjust backlighting to two different levels of intensity by pressing and releasing the POWER key repeatedly. The intensity increases incrementally when the POWER key is pressed.

First Time Use - Initializing the Receiver

The constellation of 24 GPS satellites circling the globe is in constant motion and before your receiver can tell you where you are, it needs to know where the satellites are relative to itself. Your receiver's internal almanac tells it which satellites are in view at a given geographic position.

Therefore, you need to enter your approximate location, time and date, which will serve as a point of reference for your receiver in selecting the best satellites to use. Without knowing its approximate location, the receiver may take 10 minutes or more to find the specific coordinates of your position.

Telling your receiver the initial position, time and date is called *initializing* your receiver; initializing enables it to begin tracking satellites and, therefore, calculate your position much faster.



You need not reinitialize your receiver each time you use it, but only if the unit has moved over 300 miles without computing a position or if the total memory has been cleared by the user. If you do not reinitialize, the receiver may take 10 minutes or more to compute a new position fix.

Entering an Approximate Initial Position. To give your receiver an approximation of its current position, you will need to enter the latitude and longitude of your general location. The NAV 6000 allows you to enter the location quickly and easily using the *MAP* screen.

While viewing the *Satellite Status* screen, press the INIT softkey. The Map screen appears with the cursor positioned over 0° latitude, 0° longitude (or last initialized position).

If a cartridge is inserted in the NAV 6000, the cursor will appear over the center of the cartridge's area of coverage.

Use the **CURSOR KEY** to move the cursor to your present geographic area on this map. Use the **ZOOM IN /ZOOM OUT** keys to help you determine whether the cursor is active in the right part of the globe. (Some basic knowledge of continental land masses is helpful.)

If the cursor is not in your region of the world, press **ZOOM OUT** repeatedly, then use the **CURSOR KEY** to move the cursor to your present geographic area and use the **ZOOM IN** key repeatedly to zero in on your present location.

When you have placed the cursor near your current location (within 300 miles), press **ENTER**, as you are instructed by the help bar.

The receiver records the coordinates of the cursor position where **ENTER** was pressed as the starting point from which it searches for available satellites. When it begins receiving signals from satellites, this approximate coordinate position will be updated to reflect your actual position.

Or

Press the **TYPEIN** softkey to display the **COORDINATE ENTRY** window. Use the **RIGHT/LEFT** and **UP/DOWN** arrows on the **CURSOR KEY** to enter the coordinates and press **ENTER**.

 Pressing the **QUIT** key before initializing returns to the *SAT STATUS* screen without changing the initial position.

The **ELEVATION ENTRY** window appears, prompting you for the elevation.

Use the **RIGHT/LEFT** and **UP/DOWN** arrows on the **CURSOR KEY** to enter the elevation and press **ENTER**. (If you do not know your elevation, simply press **ENTER**.)

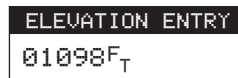

The **TIME ENTRY** window appears, prompting you for the time.

Use the **RIGHT/LEFT** and **UP/DOWN** arrows on the **CURSOR KEY** to enter the time, select **AM** or **PM** and press **ENTER**.

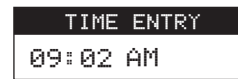

 Initialization proceeds according to the time format selected. The default format is 12-hour **AM/PM**, however, you may choose 24-hour or **UTC** time format under the **Setup Menu**. See *Setting the Time Format*

The DATE ENTRY window appears, prompting you for the date.

Use the RIGHT/LEFT and UP/DOWN arrows on the CURSOR KEY to enter the date and press ENTER. The display returns to the SAT STATUS screen.



See System Setup for instructions on changing the coordinate system.

Within seconds, after being initialized, the NAV 6000 will acquire its first position fix, displaying the actual latitude and longitude coordinates of your current position on the NAV 1 screen.



You must have a current position fix in order for the receiver to compute navigation information. If you do not have a position fix, the navigation information will be displayed with dashes until a position fix is acquired.

The format of the coordinates displayed can be changed. Latitude and longitude (LAT/LON) are expressed in ddd mm.ss, ddd mm.mm or ddd mm.mmm. The first option uses seconds (there are 60 seconds to one minute of latitude or longitude), while the second and third options use decimal format. The default format is DDD MM.MM. Other formats include: UTM, OSGB, TDs, Irish Grid, German Grid, French Grid, Swiss Grid, Swedish Grid and Finnish Grid.

Tutorial



This section will walk you through creating waypoints, creating a route, editing the route, and, finally, activating the route you created. The area chosen for this example was intentionally selected so that there is little or no land mass to interfere with the tutorial. You may follow along with your receiver, just bear in mind that coordinate values displayed in this tutorial may differ from the ones you view on your receiver.

Some of the steps and features displayed can be performed in other manners. The objective here is to demonstrate the creation of waypoints and routes using the Map Screen.

The first step is to look at the Map Screen we are going to use. The NAV 6000 has been turned on and the **NXT PG** softkey pressed, causing the Map Screen to be displayed. Next, the **HIDE** softkey is pressed to allow a larger area of the map to be displayed.

The cursor is moved with the Cursor Key until the area in which the route is to be created is displayed.

Use the **CURSOR KEY** to move the cursor to the location of a waypoint that will be used in the route.

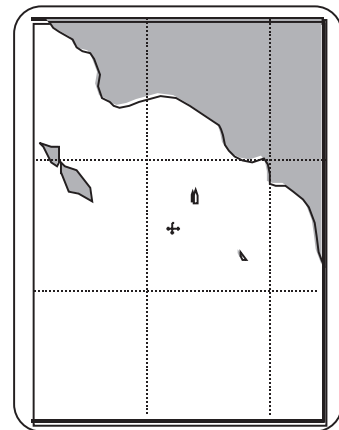

Press the **MARK** key. A MARK CURSOR POSITION window is displayed. From this window you can change the name, type, coordinates, and description for this waypoint. For this example, the information is acceptable. Press

DONE.

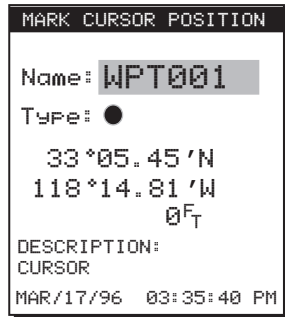

The next step is to create a second waypoint. This is done just as before; move the cursor to the desired position, press **MARK**, and accept the waypoint values from the MARK CURSOR POSITION window by pressing **DONE**.

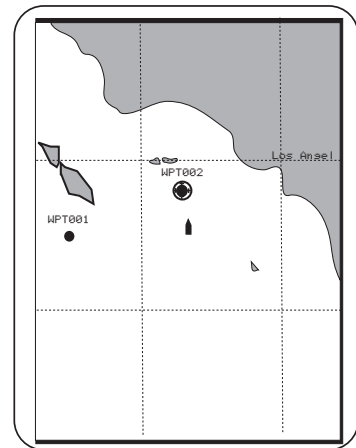

The display returns to the Map screen with the two newly created waypoints displayed.

Press any softkey to bring back the information window and the softkeys.

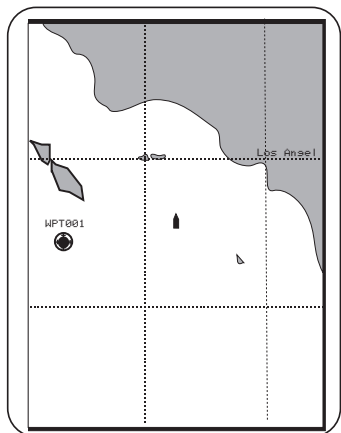

The map now resembles the one to the left with the new waypoint displayed.

Press the **ROUTES** softkey. The softkeys **LIST** and **CREATE** appear. Press **CREATE**. This is the starting point for creating a route.

The first step will be to define the starting location for the route. Move the cursor to WPT001, as this will be

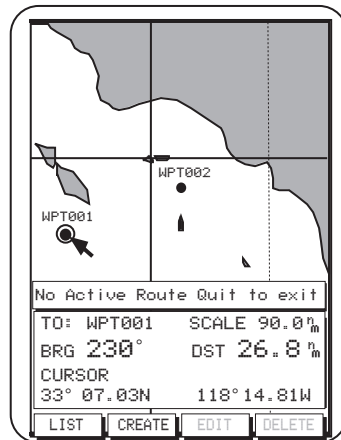
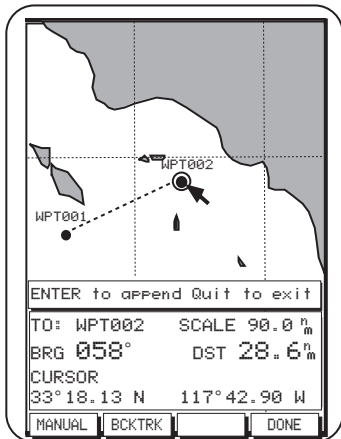

the starting waypoint for the route. Press **ENTER**.

Move the cursor towards waypoint WPT002. Notice the dashed line from WPT001 to the cursor. This helps you visualize the leg you are creating.

When the cursor is over WPT002, press **ENTER**.

This defines WPT002 as the destination for the leg being created. The dashed line becomes solid, and as the cursor is moved away from WPT002, a new dashed line is drawn.

Move the cursor to the new desired destination point. In this example there is no predefined waypoint at the position we want to use in the route.

Press **ENTER**. The receiver provides the means to create a waypoint at this point automatically. To do this, a **MARK CURSOR POSITION** (identical to the window displayed earlier) appears.

Press **DONE**.

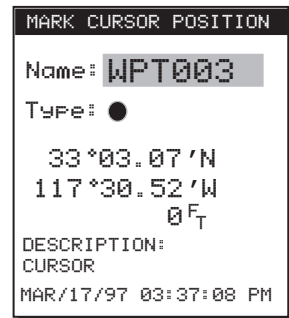
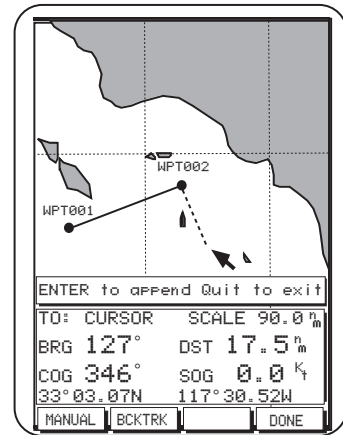

The dashed line has become a solid line. From this point, more legs could be added (appended) to the route in the same way. In this example, we have created a two-leg route. Press **DONE** to complete the Create Route function.

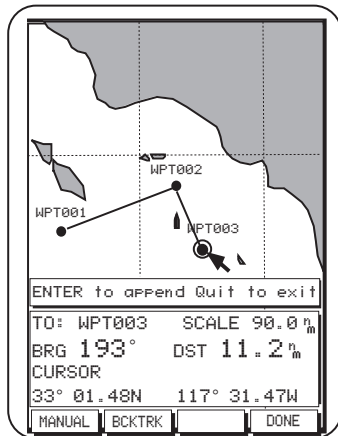

When you have moved the cursor to the new waypoint position, press **ENTER**. The waypoint has been moved and the route recalculated.

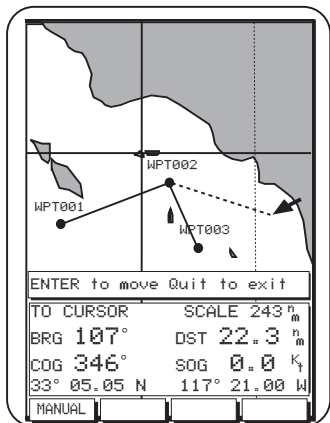
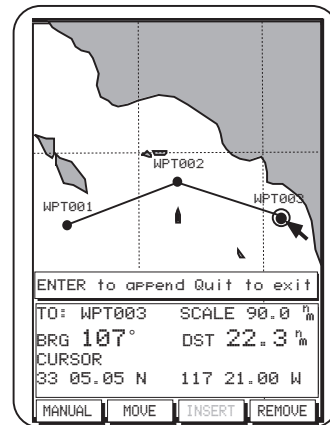

Moving a Waypoint. Press **EDIT** to access the Route Edit mode. Move the cursor toward WPT003 and when the circle appears around the waypoint, press **MOVE**. As you move the cursor away from WPT003, a dashed line aids you in placing it.

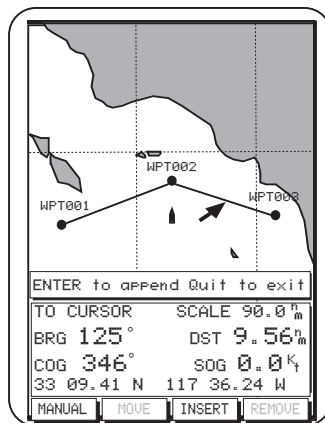

Inserting a Waypoint. A waypoint can be inserted in a route. To accomplish this, move the cursor until it is close to the leg where the new waypoint will be inserted and the Insert softkey becomes active.

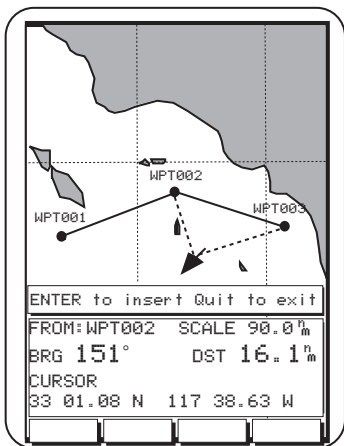

Press **INSERT**. As you begin moving the cursor, two dashed lines are displayed showing how the route is being changed.

Pressing **DONE** accepts the new waypoint and the route now resembles the one at the right.

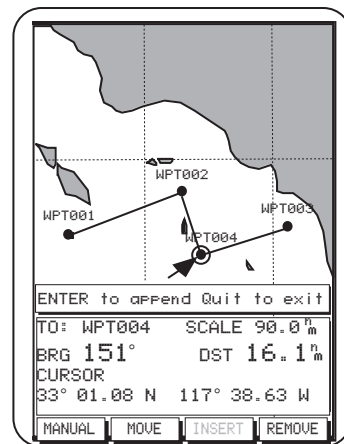

When you are satisfied with the location of the cursor, press **ENTER**. If there is an existing waypoint at that position, it will be used in the route, if not, the Insert Waypoint window will be displayed. This window behaves like the other **MARK CURSOR POSITION** windows presented in this tutorial.

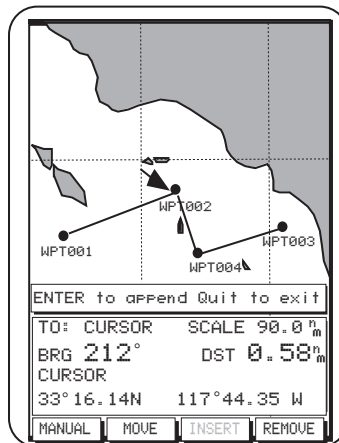
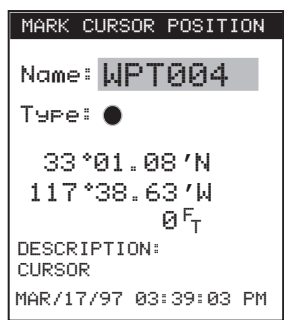

Removing a Waypoint. Another common editing function is removing a waypoint from a route. Move the cursor to the waypoint to be removed from the route. (*Please note that the waypoint is not removed from the receiver's memory, but only from this route.*)

Press **REMOVE**. WPT002 is removed from the route but is still displayed on the screen. The route has been reconfigured, starting at WPT001, to WPT004, and ending at WPT003.

Press **QUIT** to exit edit mode.

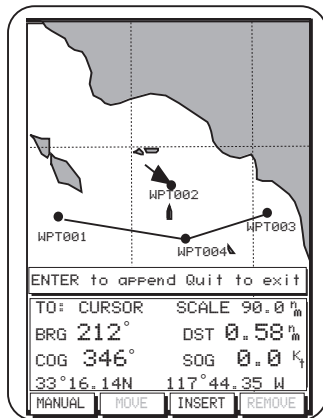

Activating a Route. A route can be activated from the route list.

From any root screen press the Routes, List softkeys. The route list appears, containing up to twenty-five routes you have created. Use the CURSOR KEY to scroll to additional pages, if any.

Highlight the route you wish to activate and press the **ACTVTE** softkey.

 Only one route can be activated at a time. Activating a route automatically deactivates the previous active route.

A window appears briefly: “Activate: Route #x is active.” Press **QUIT** twice to exit. The next time you access the Route List, the letter A appears next to the active route. The display returns to the route map screen, showing the activated route.

Deactivating a Route. An activated route can be deactivated from the route list.

From any root screen press the Routes, List softkeys.

The activated route is shown by an A next to the route number in the list. Use the CURSOR KEY to highlight the route to be deactivated, and press the DEACTV softkey.

The A next to the route in the list disappears. The selected route has been deactivated. When you return to the map screen, the deactivated route is no longer shown.

Reference



General Usage

Turning the Receiver ON/OFF

To turn power on :



Press the POWER key until the “MAGELLAN NAV 6000” and “WARNING” screens are displayed .

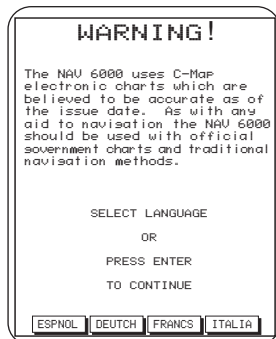

From the navigation warning screen, press one of the softkeys for a different language, or press ENTER to continue.

To turn power off :



Hold down to start countdown.

Press and hold down the POWER key to start countdown.

The receiver will begin a countdown sequence that lasts 5 seconds. The window will countdown from 4 to zero.

Pressing any key except POWER will stop the receiver from turning off. Pressing POWER after countdown starts will eliminate the countdown and turn off the unit immediately.

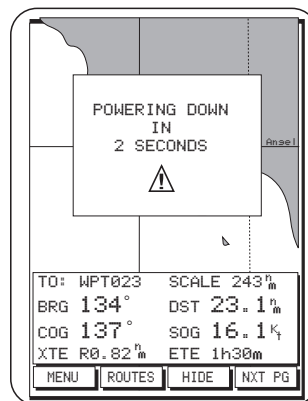

Cancelling an Operation

QUIT

Use the QUIT key to cancel and/or back out of an operation.

Inputting Data

Use the CURSOR KEY to select menu items as well as scrolling through alphanumeric series for data entry.

Use the UP/DOWN indicators on the CURSOR KEY to scroll up and down through the alphanumeric list, stopping on the selection. Then use the RIGHT/LEFT indicators on the CURSOR KEY to move the highlight to the right or left to continue or correct data entry.

Use ENTER to confirm data entry.

Adjusting Contrast



Press the MENU softkey to access the *FUNCTION MENU* screen.

Highlight System Setup and press ENTER to access the SETUP MENU, containing the Contrast option.

Use the CURSOR KEY to highlight Contrast and press ENTER.

A bar graph appears.

Use the RIGHT/LEFT arrows on the CURSOR KEY to adjust the contrast to a comfortable level, then press ENTER to confirm.

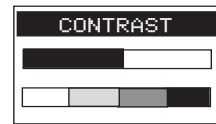

Follow the instructions at the bottom of the screen, pressing QUIT twice to back out of the Setup and Function Menu screens and return to the last viewed root screen.

Adjusting Backlighting

Adjust backlighting to two different levels of intensity by pressing and releasing the POWER key repeatedly. The intensity increases incrementally when the POWER key is pressed, and then turns off the backlight.

Root Screens

The NAV 6000 has five different “root” screens that provide you with information that you can use for navigating: *SAT STATUS*, *MAP*, *NAV 1*, *NAV 2* and *POINTER*.

From any root screen, press the **NXT PG** softkey repeatedly to cycle through the five root screens. The *SAT STATUS* screen, *MAP* screen, *NAV 1*, *NAV 2* and *POINTER* screens

are constantly updating and contain the information necessary to guide you to your destination.

You can customize the NAV 1, NAV 2 and POINTER screens to display the navigation information you find most useful (See customizing).

Root Screen Icons

At the top right of the display, on any of the root screens, these icons may appear:



indicates backlighting is on.



indicates battery strength is low.



indicates that unit satellite geometric quality is poor.



indicates differential corrections are applied to GPS position.



indicates that unit is operating on external power (not shown on the Map Screen).

Satellite Status Screen

The first screen after the navigation warning screen is the *Satellite Status* screen. This screen displays information relating to the satellites being tracked, searched for, or used in the position fix.

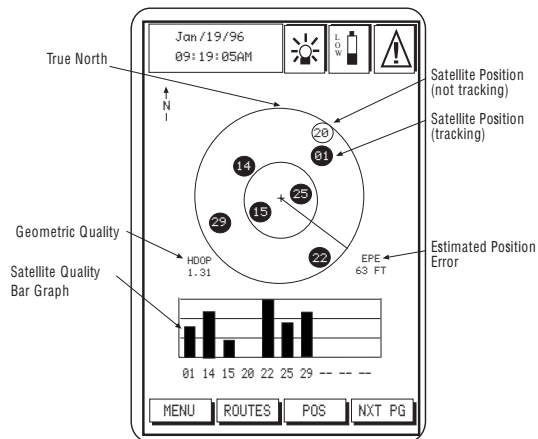

A bar graph shows the signal quality of the satellites being tracked. The satellite identification numbers are shown along the bottom of the graph, and the signal strength is represented by a bar above each satellite number. The longer the bar, the stronger the signal of the corresponding satellite.

The satellites' positions in the sky are plotted in 2 concentric circles representing 0° elevation at the horizon, and 45° . The center point of the circle, 90° , is directly overhead. The satellites being tracked are shaded.

The current time, date, geometric quality (HDOP) and estimated position error (EPE) are also displayed. When the unit is first turned on the HDOP and EPE numbers are replaced by underscores and the available softkeys are MENU, ROUTES, INIT, and NXT PG.

INIT can be used to initialize the unit (see Entering an Approximate Initial Position in Reference.)

If the receiver is computing fixes and moving faster than 0.2 mph, a line from the center to the outer circle points in the direction of COG. The direction of the line is updated whenever COG changes.

When the unit starts computing fixes, the POSITION screen will automatically be displayed.

The top of the screen displays the current GPS position. Below the position, HDOP, EPE, COG and SOG will be displayed when SOG is greater than zero. When SOG is zero, HDOP and EPE will be replaced by AVERAGING and the time over which the positions have been averaged.

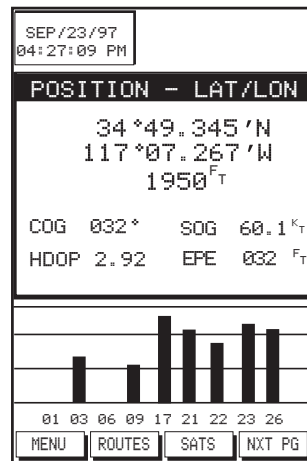

While the receiver is computing position fixes, the POS and SATS softkeys can be used to toggle between the POSITION screen and the SAT STATUS screen.

Map Screen

From the SAT STATUS screen, press **NXT PG** to access the *Map* Screen. The Map screen can also be accessed by the MAP/CTR Key from any screen.

When the *Map* Screen is viewed for the first time after the unit is turned on, the map always shows the cursor location before the unit was turned off.



If the receiver is not yet initialized, and a C-card is not installed, the cursor position defaults to 00°00.00 N and 00°00.00 W, off the African coast in the Gulf of Guinea. See Initializing.

On the bottom of the screen, an information window displays the name of the destination waypoint of the active route (if any), the bearing and distance from the present position to the destination waypoint, the cartographic scale, as well as COG, SOG, XTE and ETE, if you are moving.

Ten seconds after accessing the Map screen, the help bar disappears to show more of the map.

When the cursor is active, the coordinates of the cursor, displayed in WGS94 format, will replace the XTE and ETE.

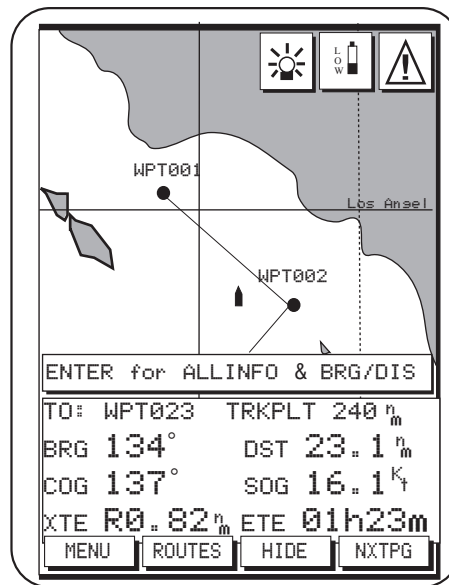

Press the **HIDE** softkey to temporarily remove the information window, extending the map to the full screen size.

Press any softkey to redisplay the information window.

When the unit computes a fix, the present position will be represented by a boat icon. If the position is more than 20 seconds old it is represented by the (X) icon.

If the last computed fix is differentially corrected, the letter D appears at the top right corner of the screen.

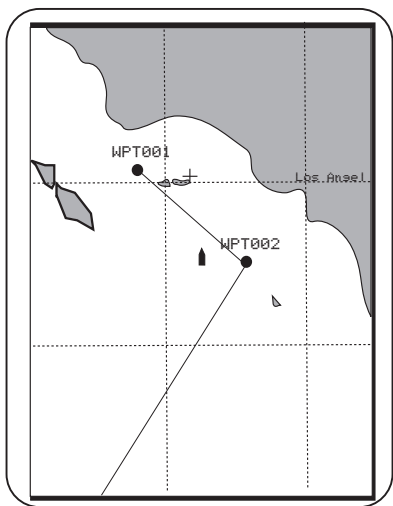

Setting the Map Scale



The map screen first appears in the highest scale setting. Use the ZOOM IN and ZOOM OUT keys to zero in on a small area of the map or pan over a larger area.

Map scale is defined as the distance across the width of the display.

The receiver retains the scale level last used when you go to view other screens or when the receiver is turned off. If the cartridge is changed, the screen will once again zoom to the highest scale.

Map scale can also be changed from the Waypoint and Route functions.

Using the Cursor Key on the Map Screen

Press the **CURSOR KEY** to activate and move the cursor on the *Map* screen.

The cursor is represented by a + .

The information window displays the bearing and distance from the present position (boat) to the cursor location (+), the coordinates of the cursor, COG and SOG.

While the cursor is active, press **MAP/CTR** to center the map around the present position boat icon. Press **MAP/CTR** again to re-center the display on the cursor.

If the boat and the cursor are shown on the screen, pressing **MAP/CTR** first centers the map around the present position and removes the cursor icon, though it remains active. Pressing **CENTER** again centers the map around the cursor and the present position boat icon is continuously updated.

 If the map is centered on the boat, pressing the **CURSOR KEY** will activate the cursor. If the cursor was already active somewhere else on the map and is not shown on the screen, that cursor position is lost.

The destination name is replaced with the word “cursor” and the cursor coordinates (WGS84 only) are displayed on the bottom line of the NAV window.

As you scroll across the map, the map will follow the cursor movement when the cursor comes near the edge. The map redraws with the cursor near the edge.

Map Orientation

The map orientation can be set to Track Up, Course Up and North Up. When North Up is selected, the boat icon rotates according to the COG direction with respect to north.

When Track Up is selected, the map turns to keep the boat icon pointing upwards. The top of the screen is then always the COG direction. The map rotates every time the COG changes more than 10°.

When Course Up is selected, the course will be displayed in the upward direction and the boat icon will rotate with the COG.

In both Track Up and Course Up modes, a north arrow will be shown at the top right corner pointing northward.

When the boat nears the edge of the screen, as position changes, it re-centers.

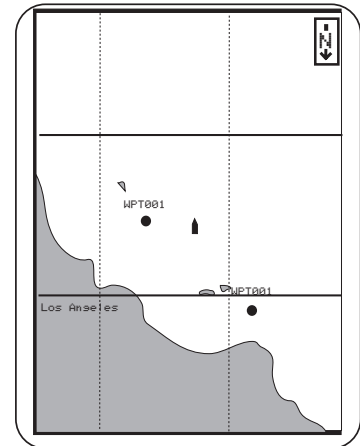

Plotter Mode

Plotter mode allows you to go where your chart does not provide detailed navigation information by displaying a LAT/LON grid without background cartography.



Though you can use this feature to plot and retrace your course conveniently using coordinates alone, **EXTREME CAUTION IS REQUIRED** when using the Plotter Mode. The Plotter Mode should never be used as a sole means of navigation. Paper charts are required.

Plotter mode can be turned on and off under the Chart Settings of Map Configuration. With Plotter mode on, if a cartridge is not installed, zooming into a scale not supported by the built-in map activates the Plotter mode and the word Scale in the NAV window is replaced by TrkPlt. If a cartridge is installed, zooming into a scale not supported by either the cartridge or the internal map also activates the Plotter mode.

The LAT/LON grid and label are turned on automatically, even if they are off in the Map Configuration. The Plotter Mode then plots the route you are traveling on a grid showing coordinates, without background cartography. A north arrow indicates the direction of north when Track Up or Course Up modes are selected.

With Plotter mode off, when you zoom into or near the lowest scale available in the cartridge, as the cursor pans over the map, you will notice that the plotter zooms out automatically when you reach an area not covered by the detailed cartography on the C-card. This feature is designed to keep cartography displayed in the background even if you “run off the edge.” Panning into an area not covered by the C-card causes the unit to zoom out to the lowest scale for which a chart is available.

When the track plot mode is entered, the following warning is given for two seconds when entering Track Plot mode:

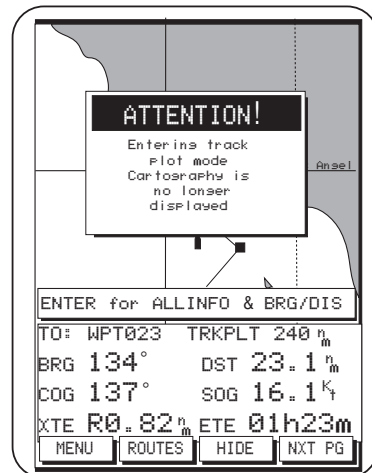

Viewing Waypoint and Navaid Attributes

When the cursor is moved over a waypoint icon, the information window displays TO: waypoint name, scale, bearing and distance to the waypoint, message (if any) and the coordinates.

 If the waypoint was created on the map using the CURSOR KEY, the message line in the information window indicates “CURSOR”. If the waypoint was created as a saved GPS position, the message line indicates “GPS”.

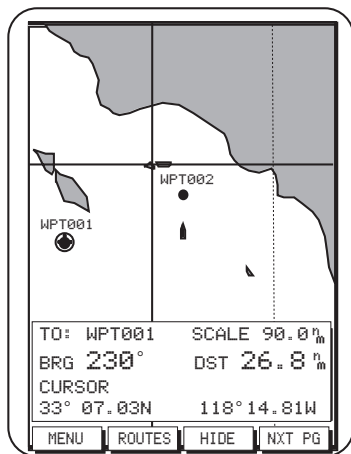

Map objects appear as icons on the map, including nav aids (buoys, signals, etc.) and other objects that are part of the cartography such as rocks, wrecks, etc. (See Appendix for list).

When the cursor covers a map object icon, object attributes appear instantly on the map screen in a QUICK INFO window, giving an abbreviated description of that object or objects. The abbreviated description is similar in format and content to what you would see in a standard paper chart.

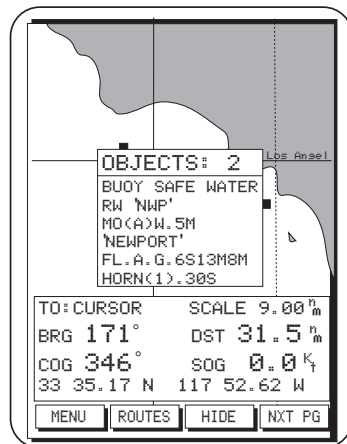

 If the cursor covers an icon in the lower portion of the screen, the QUICK INFO window opens above the icon. If the cursor covers an icon in the upper portion of the screen, the QUICK INFO window opens below the icon.

Press ENTER and the softkeys ALL INF and BRGDIS become active.

To view additional information on the Objects shown in the QUICK INFO window, press **ALLINF** and a full-screen window opens, showing a list of the objects under the cursor.

When the ALLINF softkey is pressed, the objects and their attributes appear.

Sometimes a single object, such as a floating Navigation mark, may contain several navigational aids such as a buoy, a radar transponder beacon, a light, and a fog signal. In this case, when you press **ALLINF**, the 'Navigation Mark Afloat' appears at the top of the screen and the individual nav aids are listed below along with their attributes. If there is additional information on other pages, you can use the PAGEDN softkey to display them.

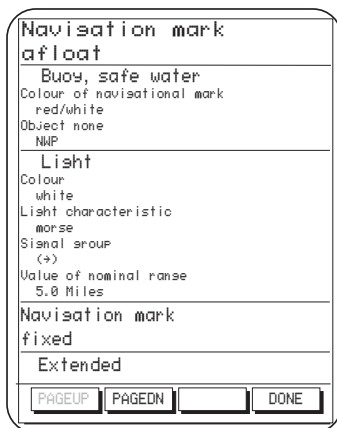

When you have finished viewing attributes, press **QUIT** or **DONE** to return to the map screen.

When using an in-land cartridge, major highways will be shown as you zoom into low scales. To obtain a detailed description of the highway, zoom into a scale lower than 10 miles and place the cursor over the highway and its description will appear on the quick information window.

Finding Distance and Bearing from a Point on the Map

You can find the distance and bearing from one point to another on the *Map* screen using a built-in “measuring stick.”



Use the **CURSOR KEY** to place the cursor on the starting reference point from which you are measuring. Press **ENTER**, **BRGDIS** or **ENTER**, **ENTER** to activate the reference point. A temporary reference point icon is created on the screen at the cursor position.

The information window heading displays “Ref Cursor.”

Use the **CURSOR KEY** to move the arrow to a second point. The bearing, distance and other navigation data displayed in the information window change as you move the cursor, drawing a dotted line between the two points.

Press **BRGDIS** again, and the reference point changes to the new cursor location, which becomes the starting point of the measurement.

Pressing **BRGDIS** when the cursor is not active sets the last computed position fix or the boat’s position as the reference point. Use the **CURSOR KEY** to move to a second point.

Press **DONE** or **QUIT** to exit the reference point feature.

NAV 1 Screen

From the *Map* Screen, press **NXT PG** to access the *NAV 1* screen.

At the top of the *NAV 1* screen is the destination waypoint (if any).

The two large center windows display Bearing (**BRG**), Distance (**DST**), Course over Ground (**COG**), Speed over Ground (**SOG**), how many degrees and direction to turn (**TRN**) and Velocity made good (**VMG**). Following this information during navigation will put you on a straight course to your destination waypoint.

Under these two windows is a Course Deviation Indicator (**CDI**). The boat icon on the **CDI** points in the direction of **COG** with respect to Bearing (**BRG**). Use the **LEFT/RIGHT ARROW**s to adjust the scale.

At the bottom of the screen are the current position coordinates and elevation, the time and date. The position coordinates are based on the setup datum, which you may select under Navigation Setup.

The active softkeys are **MENU**, **ROUTES**, **CUSTOM** and **NXT PG**.

Press **QUIT** to return to the *Map* screen or **NXT PG** to switch to the *Nav 2* screen.

Customizing the Nav 1 Screen

In addition to the navigation parameters shown, you may select SOA, XTE, ETE, BRG, COG, SOG, CTS, TRN, ETA, VMG, STR, DST and a blank field.

Press the CUSTOM softkey to activate the highlight. Use the RIGHT/LEFT ARROWS of the CURSOR KEY to change the navigation parameter as desired. Press the DOWN ARROW to move the highlight to the next field you wish to modify. When you have finished customizing all the fields you wish, press ENTER.

NAV 2 Screen

From the NAV 1 screen, press NXT PG to access the NAV 2 screen.

At the top of the screen the name of the destination waypoint (if any) is displayed.

The large center window displays Steering (STR), Distance (DST), Velocity made good (VMG), and Estimated time to arrival (ETA). Following this information during navigation will allow you to reach your destination by staying close to your planned route. These fields can be changed to include other information using the CUSTOM softkey.

The bottom of the NAV 2 screen displays a Course Deviation Indicator (CDI). Use the LEFT/RIGHT ARROWS to ad-

just the scale. The boat icon on the CDI points in the direction of COG with respect to Bearing (BRG).

The active softkeys are MENU, ROUTES, CUSTOM and NXT PG.

Press QUIT to return to the *Map* screen or NXT PG to go to the *Pointer* screen.

Customizing the Nav 2 Screen

In addition to the navigation parameters shown, you may select CTS, STR, SOA, XTE, ETE, ETA, BRG, DST, TRN, VMG, COG, SOG, CTS, TRN and a blank field.

Press the CUSTOM softkey to activate the highlight. Use the RIGHT/LEFT ARROWS of the CURSOR KEY to change the navigation parameter as desired. Press the DOWN ARROW to move the highlight to the next field you wish to modify. When you have finished customizing all the fields you wish, press ENTER.

Pointer Screen

From the *NAV 2* screen, press **NXT PG** to access the *Pointer* screen.

The *Pointer* screen provides a graphic compass in combination with a *CDI* and customizable Nav information.

At the top of the screen the name of the destination waypoint (if any) is displayed.

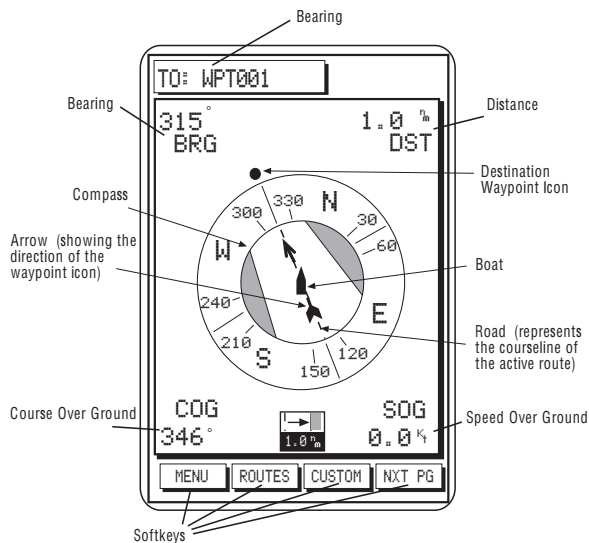

The compass shows North, South, East and West designators and overlays a road representing the course line of the active route. Along the outer edge of the compass is the destination waypoint icon. The boat icon appears in the center of the compass, pointing in the direction of motion. When BRG and COG are equal, the boat icon and the arrow will point straight up. As the boat moves away from the active course line, the road will shift to the right or left accordingly. If you are off course, the road will not appear on the screen and the Destination Waypoint Icon will represent the direction you should head to get back on course. If the unit is not computing fixes, due to poor signal reception, the Pointer screen displays graphics based on the last COG.

Bearing (BRG), Distance (DST), Course Over Ground (COG), and Speed Over Ground (SOG) are displayed in the corners of the screen. These fields can be changed to include other information using the **CUSTOM** softkey. The active softkeys are **MENU**, **ROUTES**, **CUSTOM** and **NXT PG**.

The scale of the *CDI* (distance between the course line and the edge of the road) is found at the bottom of the screen and can be changed using the right/left arrows.

Press **QUIT** to return to the *Map* screen or **NXT PG** to go to the *Satellite Status* screen.

Waypoints

The Waypoints function allows you to store in memory up to 500 positions, which can be used to build routes by which you navigate.

Waypoints can be created, viewed, edited, deleted, moved, and listed by proximity to the cursor or present position.

Waypoint names can be generated by the receiver or created by the user. In addition, you may choose from 19 different waypoint types, whose icons appear on the map, making them more easily identifiable.

From any root screen, press the MENU softkey, use the UP/DOWN ARROWs on the CURSOR key, if necessary, to highlight Waypoints, then press ENTER.

The Waypoints list appears. This list may continue for several pages if you have stored a large number of waypoints.

Use the CURSOR KEY to scroll up and down the list of waypoints. When the highlight reaches the bottom of a page, it automatically continues on the next page, if one exists. When scrolling up, the highlight automatically continues on the previous page if one exists.

The softkeys available from this screen are the VIEW, NEARST, FIND, and DELETE keys.

Press the QUIT key to exit from the Waypoints screen and return to the root screen.

Creating a Waypoint

The NAV 6000 allows you to create waypoints by pressing the MARK key from any screen to save your current coordinate position, the cursor position on the map, or manually entered coordinates. You also have the choice of allowing the unit to automatically name the waypoint, or naming it yourself.

Saving the Cursor Position as a Waypoint



Use the CURSOR KEY to move the cursor arrow to the point on the map at which you wish to create a waypoint, and press the MARK key.

The MARK CURSOR POSITION window appears.

When the name, type, coordinates and description information for the waypoint is correct, press Done.

Saving the Current Position Fix as a Waypoint



While the unit is computing fixes, from any root screen, press the **MARK** key.

The **MARK GPS POSITION** window appears.

When pressing **MARK** from the map screen while the cursor is active, **MARK CURSOR POSITION** appears; press the **GPS** softkey to display the current computed position coordinates. The window header now reads “**MARK GPS POSITION.**”

You may modify any of the four fields in the **MARK POSITION** window. Press **DONE** to accept the waypoint.

Modifying Waypoint Data Fields

Each of the four fields in the **MARK POSITION** window can be modified. Each field is assigned a default value determined by the way in which the window was accessed. You can modify a field or accept the default values.

To modify one of the fields, use the **CURSOR KEY** to highlight the field you wish to modify and press **ENTER**.

The highlight on the first character in the field becomes active. Press up or down on the **CURSOR KEY** to scroll through

the alphanumeric character list, press left or right to move the cursor to the next character.

If you want to clear the entire name or description line press the **CLEAR** softkey.

If you want to restore the name or description field to what it was at before you made these changes press the **UNDO** softkey. This will not restore the field to its default value, but to whatever value it was when you pressed **ENTER** to begin this edit.

When you have completed editing the field, press **ENTER**. You may now use the **CURSOR KEY** to move to another field.

Notes on the Data Fields

Name: A receiver-generated name is automatically generated in the format **WPTXXX** where **XXX** is a sequential number (001, 002 etc.). This name may be changed to any eight character name.

Type: A • type (icon) is generated as a default for the waypoint. You may change it to anyone of 19 different icons (Dot, Fish, Buoy, Light, Anchor, Flagstaff, Red Daymark, Green Daymark, Wreck, House, Star, Boat, Fuel, Danger, Diver Down, Food, Windward Mark, Leeward Mark and Reaching Mark).

Coordinates: The coordinates may be modified in the manner described. You can press the Cursor or GPS softkey to automatically assign the cursor position or current GPS position fix to the coordinate field. The header of the MARK POSITION window tells you which coordinates are displayed, CURSOR GPS or USER ENTERED.

Description: You may enter any description you desire up to 16 characters in this field. The default description is CURSOR or GPS.

Finding a Waypoint in the Waypoint List

From the List screen, you may perform a search to call up a certain waypoint by name. This is particularly useful if you have many pages of stored waypoints and you know the name or type of the one you are looking for.

From the Waypoint List, press the FIND softkey. The Find Waypoint window is displayed.

Searching by Name. Press ENTER with the Name field highlighted. Use the CURSOR KEY to enter the complete name of the waypoint you are looking for. Press ENTER when done and the receiver returns to the Waypoint List with the waypoint highlighted.

 The receiver's "fast search" will allow you to select only names that are in the waypoint list. While you are scrolling through the character list, characters that would spell a waypoint name that is not in the list are skipped.

Searching by Type. Alternatively, you can find one or a series of waypoints having a given icon type. Use the CURSOR KEY to highlight the TYPE field and press ENTER.

The Select Wpt Type window appears, displaying only the waypoint icon types currently in use. Use the CURSOR KEY to highlight the type of the waypoint you wish to find. Press ENTER when you have selected the icon and the receiver shows all the waypoints with the icon you selected.

To return the Waypoint List to its default configuration (all waypoints displayed) press QUIT.

Viewing a Waypoint from the Waypoint List

This function enables you to view a waypoint from the Waypoint List on the *Map* screen.



From any root screen, press MENU, highlight Waypoints and press ENTER.

Use the CURSOR KEY to highlight the waypoint you wish to view and press the VIEW softkey.

The display returns to the *Map* screen, with the selected waypoint in the center of the map, under the cursor.

The information window at the bottom of the map shows the waypoint name, scale, bearing/distance from the present position to the waypoint being viewed, message and coordinates.

Editing a Waypoint from the Waypoint List

This function enables you to change the name, icon, coordinates, and/or description of a previously saved waypoint.



From any root screen, press the MENU softkey, highlight Waypoints and press ENTER. Use the CURSOR KEY to highlight the waypoint in the list you wish to edit.

Press ENTER to edit the highlighted waypoint. The EDIT WAYPOINT window appears. You can change the waypoint name, waypoint icon, coordinates, description, or you can accept the default values. When the information for the waypoint is correct, press Done.

Deleting Waypoints from the Waypoint List



From any root screen press MENU, highlight Waypoints and press ENTER.

Use the CURSOR key to highlight the waypoint you wish to delete, then press the DELETE softkey.

The DELETE WPT screen appears showing three fields:



Use the CURSOR key to highlight one of the options and press ENTER to select.

One of the following confirmation screens appears.

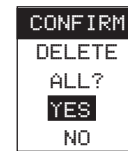



If the name field is selected, only the waypoint shown is deleted.

If the type field is selected, all waypoints with the selected icon type will be deleted.

If ALL is selected, all waypoints will be deleted.

Highlight YES to delete or NO to exit and press ENTER.

 If a waypoint is contained in a route, it cannot be deleted without first removing the waypoint from the route.

 A waypoint can also be deleted from the Map screen when you are using the VIEW waypoint function. The Delete softkey will become active and you can then delete individual waypoints by pressing DELETE when they are covered by the cursor key.

Listing the Nearest Waypoints

The Nearest function, available from the Waypoints screen, allows you to view the list of waypoints in order of proximity to your present position or to the cursor position.



From any root screen, press MENU, highlight Waypoints and press ENTER. The waypoint list appears. Press the NEARST softkey.

The waypoint list is in order of proximity to the cursor on GPS positions. The screen header indicates whether they are nearest to the cursor position or to your present GPS position (boat). A softkey GPS/CURSOR allows you to toggle between the two.

Other softkeys available on the Nearest screen are VIEW, LIST, and DELETE. Press LIST to return the display to the Waypoints screen with the waypoints in the original order.

As the help bar indicates, you may Review/Edit a waypoint in the Nearest list as you would in the Waypoint List (See Editing a Waypoint).

Moving a Waypoint

A waypoint can be moved to a different location on the Map screen when you are using the VIEW waypoint function.



From any root screen, press MENU, highlight waypoints and press ENTER. Use the CURSOR key to highlight the waypoint you wish move and press VIEW. The Map screen is displayed, centered on the waypoint you wish to move.

Press the **MOVE** softkey.

As the help bar indicates, move the **CURSOR KEY** to the new position on the map where you wish to move the selected waypoint.

As you move the cursor to a new position, a dotted line appears between the old location and the new. Navigation data in the information window at left shows the bearing and distance of the new location with respect to the old, updating the coordinates as you move the cursor.

When you have positioned the cursor at the desired new location, press **ENTER**.

 A waypoint used in a route can be moved, however, a warning appears to inform you that the waypoint is contained in a route.

Routes

A route is a planned course of travel defined by a series of waypoints stored in the receiver's memory. These waypoints are then connected to form the segments or "legs" of the route.

There are two kinds of routes: a **GOTO** route and a multi-leg route. A **GOTO** is a simple one-leg route, while a multi-leg route may contain up to thirty legs.

The NAV 6000 allows you to create and store up to twenty-five multi-leg routes, which can be activated, deactivated, viewed, reversed, edited, copied or deleted.

Creating a **GOTO** Route Using the Waypoint List



Press **GOTO** from any screen. The *Map* screen appears and the active softkeys are **LIST**, **NEARST**, **FIND** and **MOB**.

To select from the list of waypoints, press the **LIST** softkey.

Use the **CURSOR KEY** to highlight the desired destination waypoint from the list and press **ENTER**.

 Creating a **GOTO** route automatically deletes any previous **GOTO** route and deactivates any previously active routes. If the previous **GOTO** route was a **GOTO MOB**, you must confirm to delete it.

On the *Map* screen, you will notice a solid line showing the **GOTO** route created from the current position (boat icon) to the selected waypoint.

Creating a GOTO Route Using the Nearest List

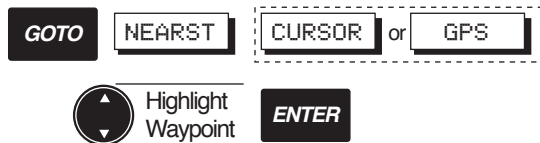

Press **GOTO** from any screen. The *Map* screen appears and the active softkeys are **LIST**, **NEARST**, **FIND** and **MOB**.

To select from a list of the nearest waypoints, press the **NEARST** softkey.

Press the **CURSOR** softkey to list waypoints nearest the cursor, or the **GPS** softkey to list waypoints nearest the present position.

Use the **CURSOR KEY** to highlight the desired destination waypoint from the list and press **ENTER**.

 Creating a **GOTO** route automatically deletes any previous **GOTO** route and deactivates any previously active route. If the previous **GOTO** route was a **GOTO MOB**, you must confirm to delete it.

On the *Map* screen, you will notice a solid line showing the **GOTO** route created from the current position (boat icon) to the selected waypoint.

Creating a GOTO Route Using the Find Function



Press **GOTO** from any screen. The *Map* screen appears and the active softkeys are **LIST**, **NEARST**, **FIND** and **MOB**.

Press the **FIND** softkey to enter the name of the waypoint to which you wish to travel.

The **FIND WAYPOINT** window appears, showing the first waypoint that exists, alphabetically, in the **Waypoint** list.

Use the **CURSOR KEY** and press **ENTER** to select **NAME** or **TYPE** to find the desired waypoint.

Press **ENTER** when the desired waypoint is found and the display returns to the map screen.

 Creating a **GOTO** route automatically deletes any previous **GOTO** route and deactivates any previously active route. If the previous **GOTO** route was a **GOTO MOB**, you must confirm to delete it.

On the *Map* screen, you will notice a solid line showing the **GOTO** route created from the current position (boat icon) to the selected waypoint.

Creating a GOTO Route to the Cursor Position



Press **GOTO** from any screen. The *Map* screen appears.

Move the cursor over the desired destination point and press **ENTER**.

If no waypoint exists at the cursor position, the **MARK CURSOR POSITION** window appears.

Use the **CURSOR KEY** and **ENTER** to modify the name, type and description, if desired, and press **DONE**.

 Creating a **GOTO** route automatically deletes any previous **GOTO** route and deactivates any previously active route. If the previous **GOTO** route was a **GOTO MOB**, you must confirm to delete it.

A solid line shows the **GOTO** route created from the present position to the cursor position.

Creating a MOB Route



The **MOB**, or Man Over Board, function allows you to instantly create a **GOTO** route to the GPS position at the time you pressed the **GOTO** key and **MOB** softkey.

Press **GOTO** from any screen. The *Map* screen appears and the active softkeys are **LIST**, **NEARST**, **FIND** and **MOB**.

Press the **MOB** softkey.

A **GOTO MOB** has been created to the position at which you pressed the **MOB** softkey.

 When a **GOTO MOB** has been created, it remains in memory until you set another route or **GOTO**. A confirmation window then appears.

Deleting a GOTO Route



Press **GOTO** from any screen. The *Map* screen appears and the active softkeys are **LIST**, **NEARST**, **FIND** and **MOB**. The message window shows “Enter: Goto cursor pos Quit: exit/clear.”

Press QUIT.

The Exit GOTO confirmation window appears.

Highlight YES and press ENTER.

The GOTO is deleted.

Multi-Leg Routes

The NAV 6000 allows you to create multi-leg routes, which can be activated, deactivated, reversed, edited, copied or deleted.

Creating a Multi-Leg Route Using the Map

Use this function to create a route from existing waypoints or create them as you go on the screen.

From any root screen, press the ROUTES, CREATE softkeys.

Move the cursor over the starting waypoint and press ENTER.

Now move the cursor over the next waypoint in the route and press ENTER. A line appears on the map, connecting the first point to the second, and so on. To add to the route a cursor position that is not an existing waypoint, press

ENTER at the cursor position and the MARK CURSOR POSITION window appears; make the necessary edits and press DONE to accept adding the new waypoint to the route. Continue to add waypoints to the route until you have completed it, then press the DONE softkey.

Press QUIT to exit the routes function.

To add, insert or remove a leg in the route, see Editing Routes.

Creating a Multi-Leg Route Manually

From any root screen, press the ROUTES, CREATE, MANUAL softkeys.

The *CREATE ROUTE* screen appears showing the number of the first available route in the screen header, “CREATE ROUTE X”.

In the center window is a table where you enter waypoints to form the legs of the route. The highlight appears in the first field of the first leg in the route.

When a route is created, the table shows leg numbers, waypoint names, bearing and distance. You will notice that the numbers at the left side appear *between* the lines. This is because a leg is defined as the distance from one waypoint in the route to the next.

Press ENTER and a window displaying the waypoint list appears. Use the CURSOR KEY to select the starting waypoint of the route and press ENTER.

The selected waypoint appears in the first field.

The highlight moves down to the next line. Press ENTER, select the next waypoint from the list and press ENTER.

Continue to select waypoints to complete the route (up to 30 legs). When you have finished, press the DONE softkey.

Press DONE again and then QUIT to return to the previous root screen.

 When selecting waypoints from the list, if the list is long, you can press the FIND softkey to access the Find Waypoint function, which allows you to enter the name of the waypoint. You can also use Find Waypoint to list waypoints of a specific type in order to narrow the search process.

Activating a Route



From any root screen, press the ROUTES, LIST softkeys.

Use the CURSOR KEY to highlight the route you wish to activate and press the ACTVTE softkey.

The next time you view the route list, an 'A' appears next

to the route number and a window appears briefly: "Route X is active."

The route which was previously active, if any, has been deactivated.

When a route is activated, the unit automatically determines which leg to navigate on based on present position. If the route being activated was previously active, the unit automatically activates the leg that was previously active if it is still valid. The user can also activate a specific leg within the route under Text Edit (See Activating a Leg of a Route).

Press QUIT to exit the Routes function.

After a route has been activated, when viewing the map screen, press MAP/CTR to center the boat on the map in order to get navigation information for the route.

Deactivating a Route



From any root screen, press the ROUTES, LIST softkeys.

Use the CURSOR KEY to highlight the activated route that you wish to deactivate and press the DEACTV softkey.

The 'A' to the left of the route number in the list disappears and the route has been deactivated.

The display remains on the Route list screen.
Press QUIT twice to exit the Routes function.

Reversing a Route from the List



From any root screen, press the ROUTES, LIST softkeys.
Use the CURSOR KEY to highlight the route you wish to reverse and press the REVERS softkey.

The route is reversed.

Press QUIT twice to exit the Routes function.

Editing a Route

Editing a route allows you to insert, delete, append, replace and move waypoints in a route.

Inserting a Waypoint in a Route on the Map

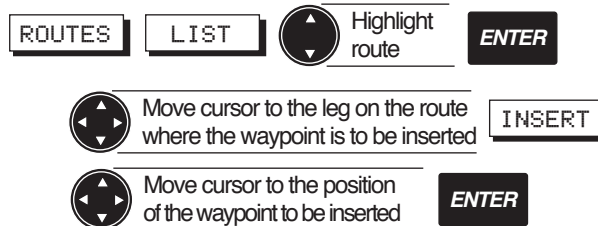

If the chosen position is not an existing waypoint, a window will be displayed to create a new waypoint for that position.

From any root screen, press ROUTE, LIST softkeys.

Use the CURSOR KEY to highlight the route in which you wish to insert a waypoint and press ENTER.

 To edit the *active* route a shortcut is to press ROUTES, EDIT.

Use the CURSOR KEY to move the cursor close to the course line near the point you wish to insert a waypoint in the route.

The INSERT softkey becomes active.

 The cursor must be in close proximity to the course line in order for the INSERT softkey to be active on the screen.

Press the INSERT softkey, then use the CURSOR KEY to move to the exact position you want to insert an existing or to-be-created waypoint. Press ENTER.

If a waypoint does not already exist at that point, the MARK CURSOR POSITION window appears.

Press ENTER and use the CURSOR KEY to modify the name, type and description if desired.

 If you want to add an *existing* waypoint to the route, you must still move the cursor near the course line, activate the INSERT softkey, then move the cursor to the waypoint to insert and press ENTER.

When you have finished, press the DONE softkey.

The inserted waypoint appears at the position you placed it on the map. Press DONE to exit Route Edit.

Inserting a Waypoint in a Route Manually

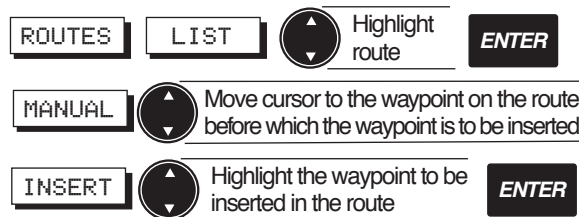

From any root screen, press ROUTES, LIST softkeys.

Use the CURSOR KEY to highlight the route in which you wish to insert a waypoint and press ENTER.

 To edit the *active* route a shortcut is to press ROUTES, EDIT.

Press MANUAL and the Routes screen appears with the first waypoint in the route highlighted.

Use the CURSOR KEY to highlight the waypoint in the route *before which* you wish to insert a waypoint and press INSERT.

The Waypoint list appears. Use the CURSOR KEY to highlight the waypoint you wish to insert and press ENTER. The display returns to the EDIT ROUTE screen and the selected waypoint has been entered.

Press DONE, QUIT to exit Route Edit.

Removing a Waypoint from a Route

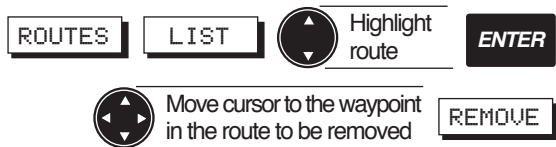

From any root screen, press ROUTES, LIST softkeys.

Use the CURSOR KEY to highlight the route from which you wish to remove a waypoint and press ENTER.

To edit the *active* route a shortcut is to press ROUTES, EDIT.

Use the CURSOR KEY to place the cursor over the waypoint in the route that you wish to remove.

Press the REMOVE softkey.

The waypoint is removed from the route, however it continues to exist as a waypoint in the waypoint list and on the map.

Press QUIT to exit Route Edit.

Appending a Waypoint to the End of a Route on the Map

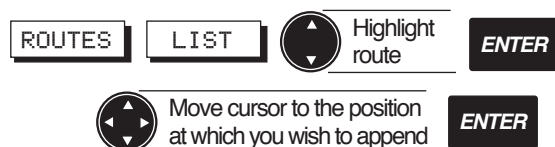

If chosen point is not an existing waypoint, a window will be displayed to create a new waypoint for that position.

From any root screen, press the ROUTES, LIST softkeys.

Use the CURSOR KEY to highlight the route in which you wish to append a waypoint to the end and press ENTER.

 To edit the *active* route a shortcut is to press ROUTES, EDIT.

Use the CURSOR KEY to place the cursor at the position where you wish to add a waypoint to the end of the route.

The help bar indicates “ENTER to append Quit to exit.”

Press ENTER.

If a waypoint does not exist at the cursor position, the MARK CURSOR POSITION window appears. Press ENTER and use the CURSOR KEY to modify the name, type and description if desired. When you have finished,

press the DONE softkey. Press QUIT to exit Route Edit.
The waypoint you created or selected at the cursor position has been added to the end of the route.

Appending a Waypoint to the End of a Route Manually

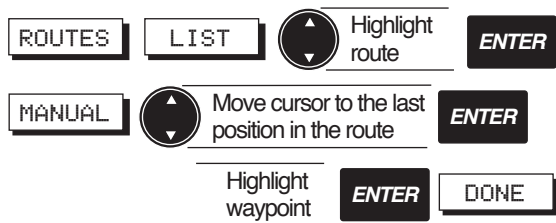

From any root screen, press the ROUTES, LIST softkeys. Use the CURSOR KEY to highlight the route in which you wish to append a waypoint to the end and press ENTER, MANUAL.

 To edit the *active* route a shortcut is to press ROUTES, EDIT, MANUAL.

Use the CURSOR KEY to place the highlight at the end of the route list.

Press ENTER.

Select a waypoint from the list (using the NEARST or FIND function if desired) and press ENTER. Press DONE, QUIT to exit Route Edit.

 If the list is very long, you may access the Find Waypoint function in this list by pressing the FIND softkey. You may also list the waypoints in order of proximity to the present position by pressing NEARST.

Moving a Waypoint in a Route

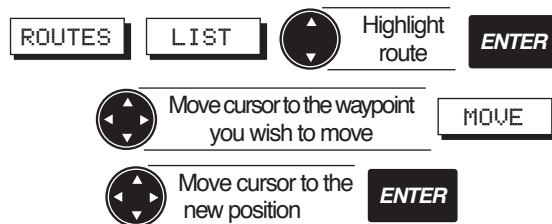

From any root screen, press the ROUTES, LIST softkeys. Use the CURSOR KEY to highlight the route in which you wish to move a waypoint and press ENTER.

 To edit the *active* route a shortcut is to press ROUTES, EDIT.

Use the CURSOR KEY to highlight the waypoint in the route that you wish to move and press the MOVE softkey.

Now use the **CURSOR KEY** to move the cursor to the position to which you wish to move the waypoint and press **ENTER**. If the waypoint being moved is at the start of the route, as you move the **CURSOR KEY**, the distance and bearing from the cursor to the next waypoint is updated continuously. If the waypoint being moved is in the middle or at the end of a route, the bearing and distance shown is from the previous waypoint to the cursor position.

The waypoint is moved from the old position to the new. Waypoints are movable, whether or not they are contained in an active route. Press **QUIT** to exit Route Edit.

Use the **CURSOR KEY** to highlight the waypoint you wish to replace and press **ENTER**.

The waypoint list appears.

Select the waypoint you wish to use to replace the one you highlighted and press **ENTER**.

The waypoint you select in the waypoint list replaces the one you highlighted in the route.



If the list is very long, you may access the Find Waypoint function in this list by pressing the **FIND** softkey. You may also list the waypoints in order of proximity to the present position by pressing **NEARST**.

Replacing a Waypoint in a Route Manually

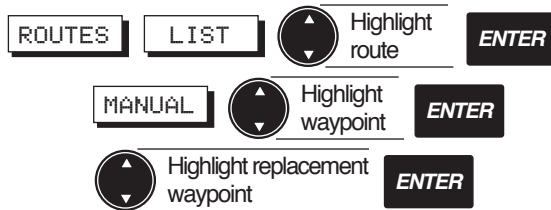

From any root screen, press the **ROUTES**, **LIST** and use the **CURSOR KEY** to select the route in which you wish to replace a waypoint. Press **ENTER**, **MANUAL**.

Activating a Leg of a Route



From any root screen, press the **ROUTES**, **LIST** and use the **CURSOR KEY** to select the route in which you wish to activate a leg. Press **ENTER**, **MANUAL** then use the **CURSOR KEY** to highlight the destination waypoint of the leg you wish to activate in the route.



If you wish to replace a waypoint in the active route, simply press **ROUTES**, **EDIT**, **MANUAL** softkeys.

Press the ACTVTE softkey.

If a leg is activated, an A appears next to the leg.

The ACTVTE softkey then changes to DEACTV.

Activating a leg of an inactive route automatically activates the route itself. Any multi-leg route which was previously active is deactivated.



To deactivate the route you can use the DEACTV softkey.

Deleting a Route on the Map



While viewing a route on the *Map* screen, press the ROUTES, DELETE softkeys.

A confirmation window appears.

“Delete Route #X? YES NO”

Highlight YES and press ENTER.

The route you were viewing is deleted (The waypoints, however, remain in memory).

Deleting a Route in the List



From any root screen, press the ROUTES, LIST softkeys.

Use the CURSOR KEY to highlight the route you wish to delete and press the DELETE softkey.

A confirmation window appears.

“Delete Route # X? YES NO”

Highlight YES and press ENTER. The route is deleted.

Copying a Route



From any root screen, press the ROUTES, LIST softkeys.

Use the CURSOR KEY to highlight the route you wish to copy and press COPY.

A window appears briefly: “Route # x was copied to route # y” and the display returns to the route list.

The highlighted route is copied to the first available route.



If there are already 25 existing routes, the Copy function is not available. You must first clear a route before copying.

Creating a Backtrack Route

When Track History is on, the unit drops “bread crumbs” at every travelled interval as set under Track History. Activation of backtrack automatically creates a route that starts from the last point recorded to the first point in track history memory. By following this route, you “retrace your steps” back to the starting position. Using all the track history points in memory, the unit calculates a route consisting of legs at least 0.2 nm in length. Once backtrack is activated, the destination point of the first leg is LEGxxx, where xxx is a number from 1 to 999, depending on how many legs are in the route. For example, let’s say our first destination point is LEG 50. Once that destination point is reached, the unit will then switch to the next leg which has a destination name of LEG 49. This count-down continues until the last destination is reached and then the unit will indicate ARRIVED. Note that a backtrack route is not the same as a regular route in that it cannot be edited, reversed or copied.

 Once a backtrack route is activated, the unit will stop recording track points. Track point recording will only resume after deactivating the backtrack route.

 When simulation is turned on the unit stops recording track points. Track point recording will only resume after turning off simulation.

Activating a Backtrack Route



To activate backtrack, from any root screen press the ROUTES softkey, CREATE, BCKTRK.

An alternative way to activate backtrack is from the ROUTE LIST screen. From any root screen, press ROUTES, LIST, ACTVTE.

Deactivating a Backtrack Route

To deactivate backtrack, from any root screen press ROUTES, LIST, highlight BACKTRACK on the list and press DEACTV. Activating any other route will also automatically deactivate backtrack.

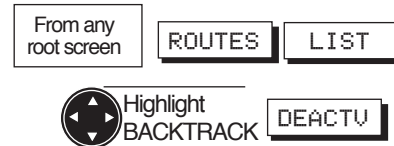

Menu Functions

The NAV 6000 offers various menu functions that are accessible from any of the navigation screens by pressing the MENU softkey. From the FUNCTION MENU you can access the Waypoints list, System Setup, Alarms, Map Setup, Track History, Trip Planning, Sun/Moon, Simulation mode, and Memory Reset.

System Setup

System Setup allows you to set screen contrast, time and date format, select a coordinate system, map datum, and elevation mode, select units, north reference, velocity averaging, port setup, and activate and deactivate the beeper.

To access System Setup, press the MENU softkey from any navigation screen, highlight System Setup and press ENTER.

The SETUP MENU appears. To select the desired function, scroll down to highlight the function using the CURSOR KEY, then press ENTER.

To exit the SETUP MENU, press QUIT.

Adjusting Contrast

The contrast can be changed for best screen viewing.

Press the MENU softkey from any of the navigation screens, highlight System Setup and press ENTER.

The SETUP MENU appears. Highlight Contrast using the CURSOR KEY, then press ENTER to display the contrast scale adjustment bar.

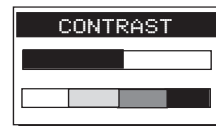

Use the CURSOR KEY to change contrast and press ENTER to confirm. Press QUIT to exit.

Default setting: 50%

Setting Time Format

Time can be referenced to either Universal Time Coordinates (UTC, Greenwich Mean Time in Greenwich, England) or local time. For local time, you can select 12-Hour (AM/PM) or 24 Hour.

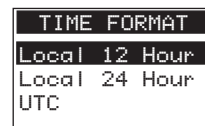

Press the MENU softkey from any of the navigation screens, highlight System Setup and press ENTER.

The SETUP MENU appears. Use the CURSOR KEY to highlight Time Format, press ENTER and a window opens that lists Local 12 Hour, Local 24 Hour and UTC.

Use the CURSOR KEY to select an option and press ENTER.

Press QUIT to exit.

Default setting: Local 12 hour

 If the local time displayed on the root screens is incorrect you may enter the correct local time by highlighting Local 12-Hour or Local 24-Hour and pressing ENTER. A window appears that allows setting the correct time. Press ENTER when done.

Setting Date Format

Date can be shown as Month-Day-Year or Day-Month-Year.

Press the MENU softkey from any of the navigation screens, highlight System Setup and press ENTER.

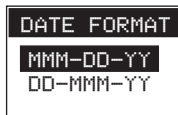

The SETUP MENU appears. Use the CURSOR KEY to highlight Date Format, press ENTER and a window opens showing the two date format options: MMM-DD-YY and DD-MMM-YY. Use the CURSOR KEY to select a format and press ENTER to accept. Press QUIT to exit.

Default setting: MMM-DD-YY.

Selecting Coordinate System

Position coordinates displayed on the NAVI screen and waypoint coordinates displayed on the waypoint screen can be based on latitude/longitude, Universal Transverse Mercator (UTM), Ordinance Survey of Great Britain (OSGB) Loran TD's, Irish, Swiss, French, German, Swedish, or Finnish Grid.

If latitude/longitude is selected, the position can be displayed in Degrees, Minutes and fractions of minutes to 2 or 3 digits of resolution, (DDD MM.MM or DDD MM.MMM) or Degrees, Minutes, Seconds (DD MM' SS").

 The important difference between Deg/Min/Sec and Deg/Min/Fractions is that there are 60 seconds in one minute of latitude or longitude (the seconds value will always be between 00 and 59), whereas fractions of a minute are expressed in decimal format (from .00 to .99, or .000 to .999).

Press the MENU softkey, from any of the navigation screens, highlight System Setup and press ENTER.

The SETUP MENU appears. Use the CURSOR KEY to highlight Coord System, press ENTER and a window opens showing the COORD SYSTEM options.



Use the CURSOR KEY to highlight desired coordinate system and ENTER to set.

If TD's is selected, the chain and pair must be chosen. Press QUIT to exit.

Default setting: latitude/longitude,
ddd mm.mm (Fractions of mins to 2 places resolution)

Selecting Map Datum

The NAV 6000 allows you to select from 73 map datums.

 All information displayed on the map screen is based on WGS84. Only position coordinates displayed on the NAV1 screen and waypoint coordinates entered manually (not through the map) are based on the map datum selected by the user through the SETUP MENU.

Press the MENU softkey, from any of the navigation screens, highlight System Setup and press ENTER.

The SETUP MENU appears. Use the CURSOR KEY to highlight MAP DATUM, press ENTER and a window opens showing the MAP DATUM options.

Use the CURSOR KEY to highlight the desired map datum and press ENTER to set.

Press QUIT to exit.

Default setting: WGS84



Selecting Elevation Mode

Press the MENU softkey, from any of the navigation screens, highlight System Setup and press ENTER. The SETUP MENU appears.

Magellan NAV 6000

Use the CURSOR KEY to highlight Elev Mode, press ENTER and a window opens showing elevation mode options.



Use the CURSOR KEY to highlight 2D or 3D (Auto) and press ENTER. In 2D, the altitude is set at the value entered under INIT. In 3D (Auto), the unit calculates the horizontal position as well as altitude if 4 or more satellites are tracked, and horizontal position only if 3 satellites are tracked.

Press QUIT to exit.

Default setting: 2D

Selecting Elevation, Distance, Speed and Depth Units

Press the MENU softkey, from any of the navigation screens, highlight System Setup and press ENTER.

The SETUP MENU appears. Use the CURSOR KEY to highlight Units, press ENTER and a window opens showing the UNITS menu: Elev, Dist, Speed and Depth.

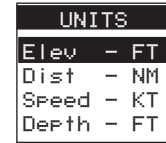

Elevation Units

From the UNITS menu, use the CURSOR KEY to highlight Elev and press ENTER.

Use the CURSOR KEY to highlight Feet or Meters and press ENTER.

Default Setting: Feet



Distance Units

From the UNITS menu, use the CURSOR KEY to highlight Dist and press ENTER.

Use the CURSOR KEY to highlight Statute Miles, Nautical Miles, or Kilometers, and press ENTER.

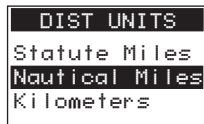

Default setting: Nautical Miles

Speed Units

From the UNITS menu, use the CURSOR KEY to highlight Speed and press ENTER.

Use the CURSOR KEY to highlight Miles per Hour, Knots or Kilometers per Hour, and press ENTER.

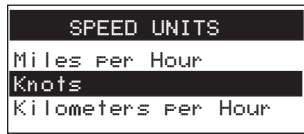

Default setting: Knots

Depth Units

Units of spot soundings and depth numbers appearing on the map can be set here. From the UNITS menu, use the CURSOR KEY to highlight Depth and press ENTER.

Use the CURSOR KEY to highlight Feet, Meters or Fathoms, and press ENTER.

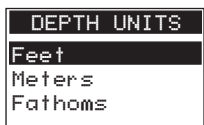

Default setting: Feet

When you have finished selecting units, press QUIT to exit.

Selecting North Reference

Direction related information such as COG, BRG, and CTS can be referenced to True North or Magnetic North.

Press the MENU softkey, from any of the navigation screens, highlight System Setup and press ENTER.

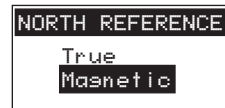

The SETUP MENU appears. Use the CURSOR KEY to highlight North Reference, press ENTER and a window opens showing the NORTH REFERENCE options.

Use the CURSOR KEY to highlight True or Magnetic and press ENTER to set.

Press QUIT to exit.

Default setting: Magnetic

Port Setup Functions

The NAV 6000 can output NMEA messages to interface with external devices such as autopilots and fish finders.

Press the MENU softkey, use the CURSOR KEY to highlight System Setup and press ENTER.

The SETUP MENU appears. Use the CURSOR KEY to highlight Port Setup, press ENTER and a window opens showing the DATA PORT options: NMEA, and Baud Rate.



Setting NMEA Output

From the DATA PORT menu, use the CURSOR KEY to highlight NMEA and press ENTER.

Output options are: Off, V1.5 APA, V1.5 XTE, V2.1 GSA.

Use the CURSOR KEY to select the desired option and press ENTER. Press QUIT to exit.

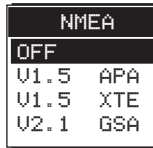

Make sure the correct baud rate is selected for the setting chosen.

Press QUIT to exit.

Default setting: OFF

Setting NMEA Baud Rate

From the DATA PORT menu, use the CURSOR KEY to highlight Baud Rate and press ENTER.

The baud rate can be set to 1200, 4800, 9600, or 19200.

Use the CURSOR KEY to select the desired baud rate and press ENTER.

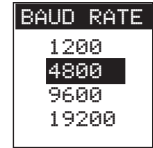

Press QUIT to exit.

Default setting: 4800

Turning the Beeper On or Off

The beeper can be turned on and off.



Beeper activation is independent of alarm control.

Press the MENU softkey, use the CURSOR KEY to highlight System Setup and press ENTER.

The SETUP MENU appears. Use the CURSOR KEY to highlight Beeper, press ENTER.

Use the CURSOR KEY to select On or Off and press ENTER.

Press QUIT to exit.

Default setting: On



Activating Alarms

The ALARMS menu allows you to set alarms for arrival radius, anchor, and cross track error. When the alarm condition is met, the beeper will sound and if an external alarm is connected, it will sound also (Beeper activation is independent from the alarm).

Press the MENU softkey, use the CURSOR KEY highlight Alarms and press ENTER. Use the CURSOR KEY to highlight the alarm to be activated and press ENTER.

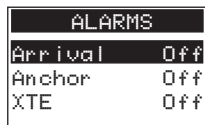

Default setting: All Off

Setting Arrival Radius

If the alarm is on, it will sound when the boat comes within a certain distance of the destination waypoint(s) of the route. The arrival radius can be set between 0.01 and 9.99 distance units.

From the Alarms menu, use the CURSOR KEY to highlight Arrival and press ENTER.

Use the CURSOR KEY to highlight On and press ENTER.

Use the CURSOR KEY to select desired radius and press ENTER. Press QUIT to exit.

Default setting: Off



Setting Anchor Alarm

While the unit is computing position fixes, the alarm will sound when the boat has moved more than a certain distance from the position where the alarm was activated. The anchor radius can be set between 0.01 and 9.99 distance units.

From the Alarms menu, use the CURSOR KEY to highlight Anchor and press ENTER.

Use the CURSOR KEY to highlight On and press ENTER.



Use the **CURSOR KEY** to select desired radius and press **ENTER**. Press **QUIT** to exit.

Default setting: Off

Setting XTE Alarm

If the alarm is on, it will sound when the boat has exceeded a certain XTE. The XTE can be set from 0.01 to 9.99 distance units.

From the Alarms menu, use the **CURSOR KEY** to highlight XTE and press **ENTER**.

Use the **CURSOR KEY** to highlight **On** and press **ENTER**.

Use the **CURSOR KEY** to select the desired XTE value and press **ENTER**. Press **QUIT** to exit.

Default setting: Off



Map Setup

The Map Setup menu enables you to change the map configuration and orientation, set course project and map shift.

Map Configuration Functions

The Map can be configured to show the objects that best suit your navigation needs. Object attributes can be viewed on the map if the object is turned on in Map Configuration.

Turning Land Settings On and Off

Land icons shown on the map can be turned on and off. They include Natural Features such as dunes, hills, vegetation, and salt pans; Rivers and Lakes; Cultural Features, such as airports, bridges, roads, railways, cables, and pipelines; and Landmarks, such as buildings, water tanks etc.

Press the **MENU** softkey, use the **CURSOR KEY** to highlight Map Setup and press **ENTER**.

Use the **CURSOR KEY** to highlight Map Configuration, press **ENTER**, highlight Land Settings Menu and press **ENTER**.

Use the **CURSOR KEY** to select the feature you wish to activate or deactivate and press **ENTER**.

A screenshot of a menu titled "LAND SETTINGS". The menu lists four categories: "Natural Features", "Rivers & Lakes", "Cultural Features", and "Landmarks". Each category has a corresponding status: "On".

LAND SETTINGS	
Natural Features	On
Rivers & Lakes	On
Cultural Features	On
Landmarks	On

Use the CURSOR KEY to highlight On or Off and press ENTER. Press QUIT to exit.

Default setting: On

Turning Marine Settings On and Off

Marine features icons shown on the map can be turned on and off. They include Water Turbulence, Depth areas (depth contours, dredged and intertidal areas); Spot Soundings, and Bottom Type.

Press the MENU softkey, use the CURSOR KEY to highlight Map Setup and press ENTER.

Use the CURSOR KEY to highlight Map Configuration, press ENTER, highlight Marine Settings and press ENTER.

MARINE SETTINGS	
Water Turbulence	On
Depth Areas	On
Spot Soundings	On
Bottom Type	On

Use the CURSOR KEY to select the feature you wish to activate or deactivate and press ENTER.

Use the CURSOR KEY to highlight On or Off and press ENTER.

Press QUIT to exit.

Default setting: On

Turning Nav-Aid Settings On and Off

Nav-Aid icons shown on the map can be turned on and off. They include Ports and Services; Attention Areas, such as caution, danger and restricted areas, and offshore installations; Tracks and Routes; Light Settings; Buoys and Beacons; Signals, such as radar, radio, and electronic positioning systems; Cartography Objects, such as generic lines, areas and texts, and Complex Object Icons, single or multiple.

Press the MENU softkey, use the CURSOR KEY to highlight Map Setup and press ENTER.

Use the CURSOR KEY to highlight Map Configuration, press ENTER, highlight Nav-Aids and press ENTER.

Use the CURSOR KEY to select the feature you wish to activate or deactivate and press ENTER.

NAV AIDS	
Ports & Services	On
Attention Areas	On
Tracks & Routes	On
Light Settings	On
Buoys & Beacons	On
Signals	On
Cartography Obj	On
Complex Obj Icons	On

Use the CURSOR KEY to highlight On or Off and press ENTER.

Press QUIT to exit.

Default setting: On

When Lights are turned ON under the NAV AIDS Menu, lights will be shown on lighthouses and other lights that rotate, and a light sector will be displayed to show the range of coverage for the light. In the No Sector setting, the light will be shown without sectors.

Use the CURSOR KEY to highlight Light Settings and press ENTER. Use the CURSOR KEY to select Off, On - No Sector, or On - Sector and press ENTER.

Default setting: On

Complex Object Icons can be set to single (individual icons for each object are superimposed on each other) or multiple (one icon represents multiple objects in the same location).

Default setting: Single - Sector

Turning Chart Settings On and Off

Chart settings on the map can be turned On and Off. They include Lat/Lon Grid; Chart Boundaries; Waypoint Icons, Track Display, Names of continents, countries and cities; Compass, showing magnetic variation information points; Chart Generation, showing chart generation and nautical publication information; New Objects defined in software upgrades; Info Level, (amount of information given for each Nav-Aid or cartographic object; can be basic or detailed) and Plot Mode (refer to Plotter Mode in the Map Section).

Press the MENU softkey, use the CURSOR KEY to highlight Map Setup and press ENTER.

Use the CURSOR KEY to highlight Map Configuration, press ENTER, highlight Chart Settings and press ENTER.

CHART SETTINGS	
Lat Lon Grid	On
Chart Boundaries	On
Waypoint Icons	On
Track Display	On
Names	On
Compass	On
Chart Generation	On
New Objects	On
Info Level	Det
Plot Mode	Off

Use the CURSOR KEY to select the feature you wish to activate or deactivate and press ENTER.

Use the CURSOR KEY to highlight On or Off and press ENTER.

Press QUIT to exit.

Default setting: On (except Plot Mode)

The Info Level can be set to Basic or Detailed.

Default setting: Detailed

Selecting Map Orientation

When navigating on the map, there are three methods of orienting the map and the boat icon.

When Map Orientation is set to North Up, the boat icon rotates according to its COG direction, with respect to north; the map does not rotate.

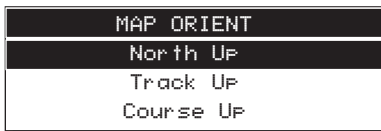

When Map Orientation is set to Track-Up, the boat icon always points up while the map rotates so the top of the screen is always the COG direction. The map rotates every time COG changes more than 10 degrees.

When Map Orientation is set to Course Up, the map is rotated so the active course line is a vertical line and the top of the screen is the bearing to the destination waypoint.

Press the MENU softkey, use the CURSOR KEY to highlight Map Setup and press ENTER.

Use the CURSOR KEY to highlight Map Orientation, press ENTER.

Use the CURSOR KEY to highlight North Up, Track Up or Course Up and press ENTER.

Default setting: North Up

Projected Course Indicator

The position of the boat can be projected ahead in time based on current velocity. The projected course is represented by a

solid line extending from the boat in the direction of its COG and terminated with an ⊕.

Press the MENU softkey, use the CURSOR KEY to highlight Map Setup and press ENTER. Use the CURSOR KEY to highlight Projected Course and press ENTER. The course can be projected ahead over 2 min., 10 min., 30 min., 1 hour, or 2 hours. Use the CURSOR KEY to highlight and ENTER to accept. Press QUIT to exit.

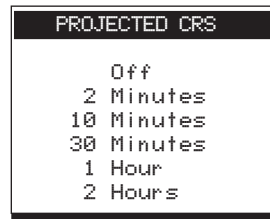

Default setting: OFF

Map Shift

The position plotted on the map screen and the electronic charts on the C-Cards are based on WGS 1984 datum regardless of the datum set. Paper charts from which electronic charts are created may be based on other datums and were shifted to WGS 1984 when the electronic charts were created. In some rare cases, the datum of the paper chart is unknown, which may cause a consistent bias (error) to appear between the displayed position and known coordinates. This bias can be corrected by using Map Shift to shift the receiver's computed position to match its coordinates on your paper chart.

 When using Map Shift, we recommend that you physically go to a position that is clearly recognizable on the paper chart, to serve as a basis for performing the shift.

Press the MENU softkey, use the CURSOR KEY to highlight Map Setup and press ENTER. Use the CURSOR KEY to highlight Map Shift and press ENTER.

The Map Screen appears. When no Map Shift has been set, the help bar indicates “No map shift entered.”

Travel to a position you recognize with certainty on your paper chart and use the ZOOM IN key to select a scale level that closely matches the paper chart’s scale. Compare this position on the paper chart with the boat position displayed on the NAV 6000. The receiver’s boat icon may appear to be far from your current position on the paper chart.

To set the bias, use the CURSOR KEY to move the cursor, active at your current GPS position, to the position corresponding to your current location on the paper chart. A dotted line is traced from your current position to the cursor. When you have finished placing the cursor, press ENTER.

As you travel, you can check to see that you have shifted the boat’s position properly by comparing other points of reference on your paper chart with the corresponding points on the electronic chart.

Pressing the Clear softkey clears the offset.

Press DONE to return to the Map Configuration screen.

Track History Functions

The Track History Function allows plotting the track of the vessel as it moves. How often the boat’s position is plotted on the map is based on distance traveled.

A total of 2000 track points can be stored, and the percentage of these points used is shown as a percentage under Track Memory Used. When the track memory is filled up, newly recorded points require the unit to automatically erase points that were first recorded.

Press the MENU softkey, use the CURSOR KEY to highlight Track History and press ENTER.



 Setting Track History Off will not remove the track history already recorded from the map. To remove the track from the map, set Track Display to Off under Map Configuration, Chart Settings.

Turning Track History On or Off

Press the MENU softkey, use the CURSOR KEY to highlight Track History and press ENTER.



The TRACK HISTORY menu appears. Use the CURSOR KEY to highlight Track History and press ENTER.

Use the CURSOR KEY to turn Track History On or Off and press ENTER. Press QUIT to exit.

Default setting: On

Choosing the Distance Resolution

Distance Resolution can be selected in the Track History menu.

Press the MENU softkey, use the CURSOR KEY to highlight Track History and press ENTER.

The TRACK HISTORY menu appears. Use the CURSOR KEY to highlight Dist Resolution and press ENTER.

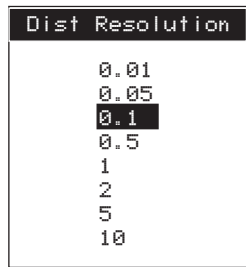

Use the CURSOR KEY to select the desired distance resolution and press ENTER. Press QUIT to exit.

Default setting: 0.1 distance units

Clearing Track Memory

Clearing track memory removes the track stored in memory that is plotted on the map. To clear track:

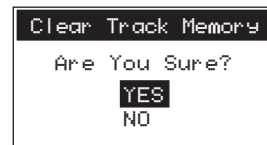

Press the MENU softkey, use the CURSOR KEY to highlight Track History and press ENTER.

The TRACK HISTORY menu appears. Use the CURSOR KEY to highlight Clear Track Memory, and press ENTER.

A confirmation screen appears. Use the CURSOR KEY to select Yes or No and press ENTER. Press QUIT to exit.

Trip Planning Function

Press the MENU softkey, use the CURSOR KEY to highlight Trip Planning and press ENTER.

The TRIP PLANNING screen appears showing the route number and message, SOG, Fuel Flow, and Departure time of the route displayed.

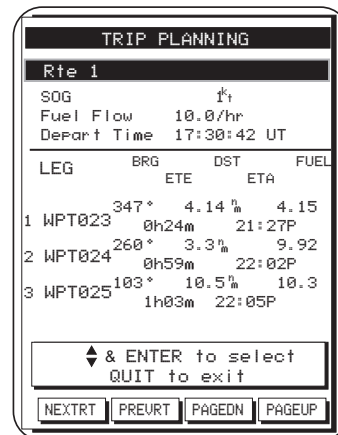

Use the CURSOR KEY to highlight one of the fields and press ENTER. Use the CURSOR KEY to edit and press ENTER to confirm.

The softkeys allow you to view the next route, the previous route, and to scroll page up and page down in the route currently displayed. The BRG, DST, ETE, ETA and fuel required for each leg is given. Press QUIT to exit.

Calculating Sunrise/Sunset and Lunar Information

The NAV 6000 allows you to view sunrise/sunset and lunar phase information for a specific position and date.

Press the MENU softkey, use the CURSOR KEY to highlight Sun/Moon and press ENTER.

The SUN/MOON screen appears with LOCATION X highlighted.

Press ENTER.

The LOCATION window appears.

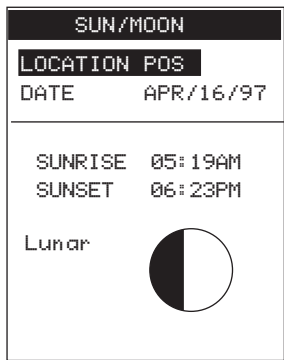

Select CURRENT POS to view sunrise and lunar information at the most recent position fix, or WAYPOINT for any other position. Press ENTER.



 If you select WAYPOINT, the Find Waypoint function appears which allows you to enter the name of a waypoint. Search by waypoint name or icon type, as described under “Finding a Waypoint in the Waypoint List.”

Press ENTER to confirm.

 When the unit is first turned on, the default setting for location is POS which is the last computed position, however, the field does not return to this value unless the unit is turned off.

When the SUN/MOON screen reappears, use the CURSOR KEY to highlight the date field and press ENTER.

Use the CURSOR KEY to change the date, if desired, and press ENTER.



Once the date is selected, the sunrise/sunset times and lunar phase information are displayed.

Press QUIT.

Simulation Mode Function

When activating the simulation mode, if a route (multileg or GOTO) is already active, that route will be used for the simulation. If a route is not already active, the unit will automatically create a route that occupies the #25 spot on the route list. This automatic route consists of waypoints having a starting waypoint “SIM-POS” surrounded by 8 waypoints aligned to the north, northeast, east, southeast, south, southwest, west and northwest directions. The boat icon starts at SIM-POS and navigates to all waypoints.

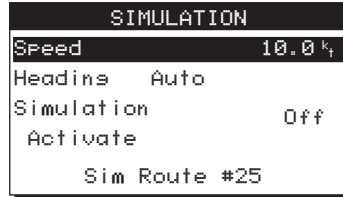

Press the MENU softkey, use the CURSOR KEY to highlight Simulation and press ENTER.

Use the CURSOR KEY to highlight Speed and press ENTER. Use the CURSOR KEY to key in a value and press ENTER.

Highlight Heading and press ENTER. Use the CURSOR KEY to choose between Auto and Manual.

If you choose Manual, you are prompted to enter the heading value. Press ENTER when you have finished.

Use the CURSOR KEY to highlight Simulation Activate and press ENTER. Use the CURSOR KEY to highlight On and press ENTER. Press QUIT to exit.

To deactivate simulation mode, simply set Simulation Activate to Off.

Memory Reset

Three options are available under Memory Reset: Clear Routes & Waypoints, Load Factory Defaults, and Clear All Memory.

Clear Routes & Waypts is used to erase all existing routes and waypoints. Load Factory Defaults changes all of the settings you have customized (units, map settings, etc.) back to the original factory settings.

Clear All Memory is used only if you wish to erase the last completed position, time, date and all user-entered information, including all waypoints, routes, track and setup. When Clear All Memory is executed, the menu functions are reset to their default values.

Press the MENU softkey, use the CURSOR KEY to highlight Memory Reset and press ENTER.

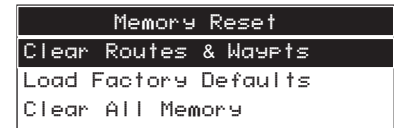

Use the CURSOR KEY to highlight the desired option and press ENTER.

A confirmation screen appears. Highlight YES and press ENTER. A message confirms the memory clear.

If you select Clear All Memory, the unit will turn off after a few seconds. Turn the unit on again to continue.

Troubleshooting

The following is a brief guide to some of the problems that might be encountered while using the Magellan NAV 6000 and what you can do to correct them.

Receiver will not turn on

- 1** If the receiver is being powered by batteries, make sure that they are fully charged. In addition, make sure that the battery door is closed and both fasteners are secured.
- 2** If the receiver is being powered externally, it may not have been hooked up correctly to external power, or the external power source is not working. Check the connections, and be sure the external power source is working. The power supply used or the circuit breaker that the unit is connected to should be rated for at least 0.5A at 12V.

Use only the Magellan Power/Data Cable to connect the receiver to external power.

- 3** Press power key.

Receiver will not compute a position fix

- 1** Make sure that the antenna at the top of the unit has a clear, unobstructed view of the sky.

- 2** If using an external antenna, check the antenna connections. Make sure the coaxial cable is firmly secured to the back of the unit. Check along the length of the cable to make sure it is not cut. With a voltmeter, you may also measure the voltage output from the unit to the antenna, which should be 5 ± 0.25 VDC between the center conductor and the shield of the SMB connector. (Make sure you don't short the center conductor and the shield while you are checking the voltage.) In addition, the antenna needs to be mounted such that it has a clear view of the sky.

- 3** Have you moved more than 300 miles with the receiver off since your last position fix? If so, the receiver may need to be reinitialized.

- 4** If the unit is not receiving any signals, turn unit off and on, then reinitialize.

- 5** If none of the above works, do a Memory Reset. Select memory Reset under Function menu and execute the "Clear All Memory."

WARNING: This will clear the unit's memory including waypoints, routes, GPS initialization, and settings.

Position coordinates on your receiver do not match the location on your map.

- 1** Make sure that your receiver is set up to use the same datum as your map. The map datum is generally shown in the map legend. See Map Datum under System Setup for instructions on selecting the map datum in your receiver.

Position fix fluctuates

- 1** Small changes in the position coordinates and elevation are normal. They are caused by several variables, including the geometric quality of the fix and the effects of SA. Geometric quality is a measurement of the probable accuracy of a fix based on the position of the satellites being used in relation to each other.

Unit does not recognize C-card installed

- 1** Make sure the C-card is mounted all the way into the C-card slot so it is locked in place.
- 2** Check the C-card contacts to make sure they are clean. If dirt is collected on the gold contacts, use a soft dry cloth to wipe the dirt away.

If you are experiencing a problem that is not described above, please contact Magellan Technical Support for assistance at

Tel.: (909) 394-5000 or Fax: (909) 394-7070. Technical Support engineers are available from 8 a.m. to 5 p.m. Pacific Standard Time.

If none of the above fixes the problem, as a last resort, you may attempt Memory Reset to “Clear All Memory,” including waypoints, routes and GPS initialization information. Clear All Memory can be done under the Function Menu - Memory Reset or if the problem is such that you can't access the Menu functions, follow this procedure:

With the unit on, press the QUIT, GOTO and MAP/CTR keys simultaneously.

```
LOST FIX ALARM
GPS Has Stopped
Computing
Fixes
-----
ENTER or QUIT to clear
```

This message appears when position fix is more than 20 seconds old. The alarm will sound when the message appears.

```
LOST EXTERNAL ALARM
External
Power
Lost
-----
ENTER or QUIT to clear
```

Is displayed when the external power becomes disconnected while the unit is on. The alarm sounds when message appears.

```
ANCHOR ALARM
Boat Has Moved
More Than X.XXnm
From The Anchor
-----
ENTER or QUIT to clear
```

Is displayed when anchor alarm is on and boat moved more than X.XX from position fix when the alarm was set on. The alarm sounds when message appears.

```
XTE ALARM
Boat Is Off Course
By More Than
X.XXnm
-----
ENTER or QUIT to clear
```

Is displayed when XTE alarm is on and the boat is more than X.XX Nm from the course line.

```
ARRIVAL ALARM
Boat Is Within
X.XX nm
of XXXXXXXX
-----
ENTER or QUIT to clear
```

Is displayed when Arrival Radius is set and the boat has moved within the arrival radius.

NAV 6000 Appendix



Installation Instructions	64
Battery Installation	64
C-Card Installation	65
Nav 6000 Swivel Mounting Bracket (Optional) ...	67
Electrical Connections	69
Connecting the DC Power/NMEA Data Cable (Optional)	69
Connecting the PC Cable (Optional)	70
Proper External Antenna Installation	71
Navaid Icons	72
List of Available Datums	77
NMEA Messages	78
Abbreviations	84
Specifications	86
Coordinate Systems	87
What Is GPS?	89
Explanation of Data Terms	91
Glossary	93

Installation Instructions

Battery Installation

The NAV 6000 comes with 6AA batteries already installed. To replace batteries, with the unit turned off, unlock the door at the bottom of the unit by turning both fasteners a 1/4 turn to the left. Remove the old batteries and insert new ones as shown, paying careful attention to the polarity. Close the door by readjusting it and turning the fasteners a 1/4 turn to the right. Even though a capacitor inside the unit can maintain memory for up to an hour, it is recommended that you replace batteries within a few minutes to avoid the possibility of losing memory.

You may use standard AA Alkaline batteries or NiCad rechargeable batteries for powering the NAV 6000. When using NiCads be aware that they discharge at a faster rate than alkaline batteries as they near a discharged state; therefore it is recommended to replace batteries once the battery icon is shown to avoid memory loss.

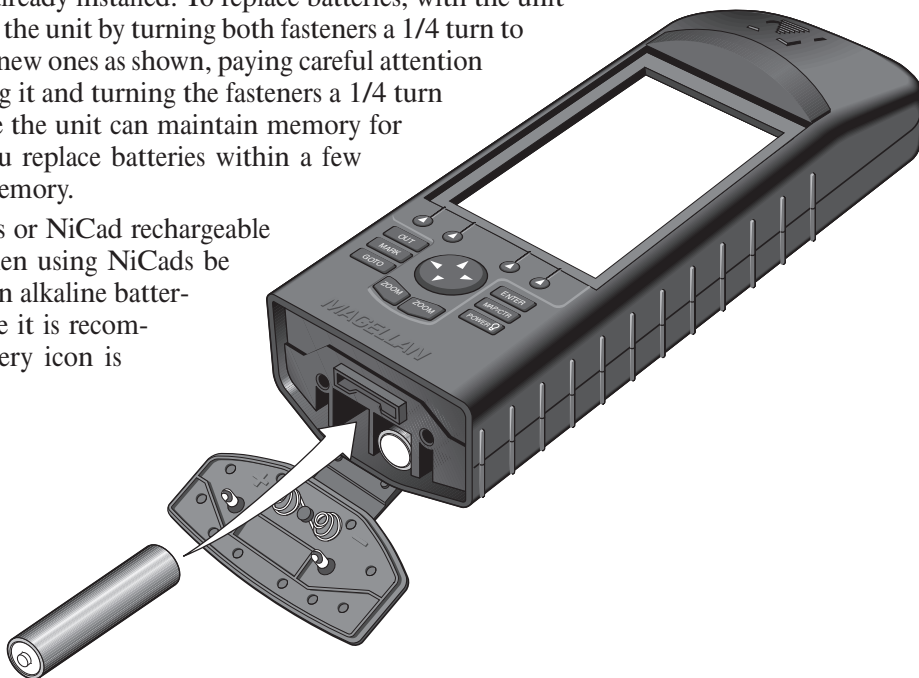

C-Card Installation

In addition to its internal chart information, the NAV 6000 displays detailed navigational chart information from external data cartridges.

A cartridge should be inserted or removed only when the unit is powered off. To insert a cartridge: while facing the bottom of the NAV 6000, unlock the bottom door by turning the fasteners 1/4 turn to the left. Insert the cartridge into the slot above the battery compartment with the “C-MAP” label on the cartridge facing up.

Push the cartridge all the way in. When it will go no further, press the edge of the cartridge down gently until it rests in place behind the plastic catch.

To remove the cartridge, turn the unit off and push the cartridge in and up gently to free it from the plastic catch. The cartridge will pop out easily. Use caution. To avoid eye damage, do not hold unit near eyes when removing the C-card. The C-card mechanism is spring-loaded and could eject the card suddenly when removing.

Data cartridges are available from your Magellan dealer or directly from C-MAP.

C-MAP

133 Falmouth Road
Mashpee, MA 02649-9910

tel. (508) 477-8010

fax (508) 477-6168

(800) 424-2627

C-MAP Italy

Via Caboto, 9
54036 Marina di Carrara

Italy

tel. 39 0585.630.703

fax 39 0585.631.282

Nav 6000 Swivel Mounting Bracket (Optional)

Before installing the NAV 6000 in its swivel mount, there are several things you should keep in mind.

The NAV 6000 should be mounted in a location where it is easily viewed, where the operating keys are accessible.

Although the NAV 6000 is splash proof, it should not be subjected to prolonged exposure to water. To protect the unit from direct sunlight and water, the case (supplied with the unit) should be used when the unit is not being operated.

We do not recommend installing the NAV 6000 within 1 foot (0.3 meters) of a magnetic compass or a flux gate sensor. (Autopilots and remote electronic compasses typically have flux gate sensors).

When deciding on a location for the swivel mount, find a surface that is fairly flat for the base plate, making sure that the unit can be viewed clearly. You will need four screws (not included) for mounting the base plate on the selected surface.

Once mounted, the unit can be turned and tilted in its base by loosening the knobs, and you can pass the power/data and antenna cables around the mount bracket and connect them to the unit.

Secure the round swivel base to the dash board or other surface using four screws.

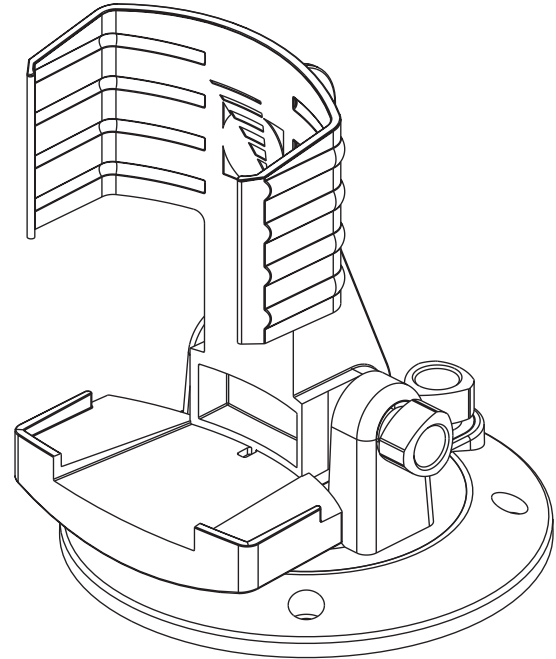

The NAV 6000 Swivel Mounting Bracket is shipped, fully assembled, from the Magellan factory. The exploded drawing at right shows the individual parts of the bracket and part numbers.

The Magellan NAV 6000 Swivel Mounting Bracket is composed of the following parts:

- | | |
|----------------|--------------|
| Holding cradle | 1 Short knob |
| Swivel | 1 Clamp |
| Base | 1 Long knob |
| 1 Hinge pin | 1 Washer |
| 2 Springs | 1 Screw |

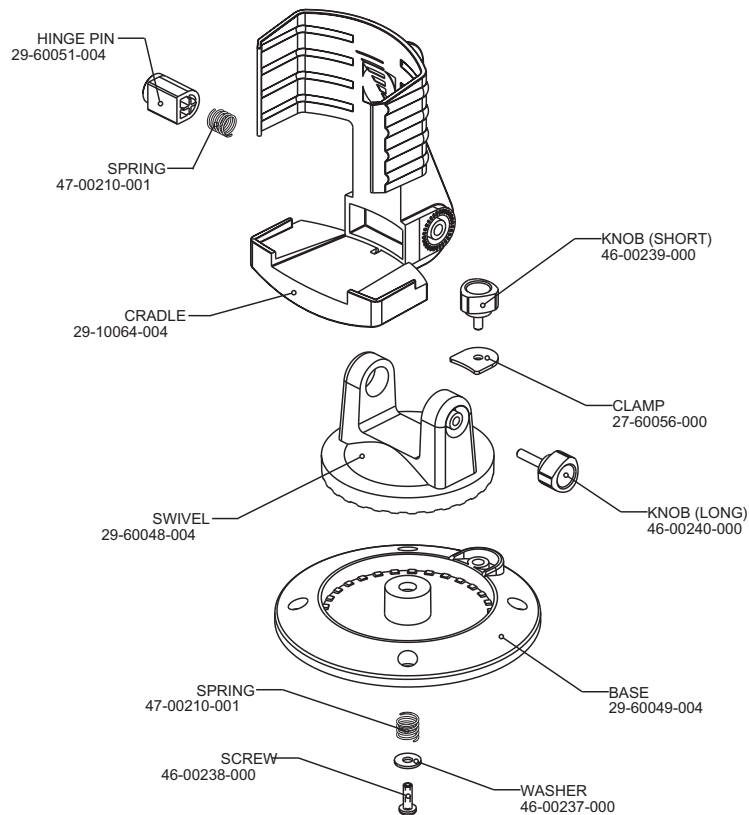

Electrical Connections

Use the power/data cable to connect the unit to an external power source and to data devices.

The NAV 6000 accepts 9-32 VDC. It is recommend, but not required, for a fuse (2A slow blow) to be connected to the positive lead of the power source. See the wiring diagram to make the necessary connections. The power/data connector on the back of the unit has the following pin-out:

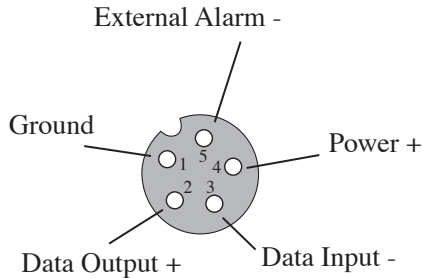

Connecting the DC Power/NMEA Data Cable (Optional)

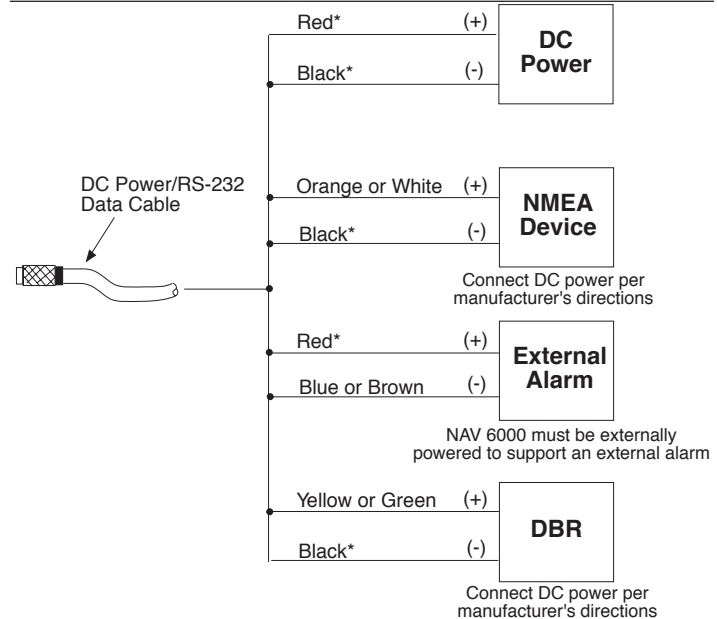

* Additional red and black wire must be spliced to connect more than one device.

Connecting the PC Cable (Optional)

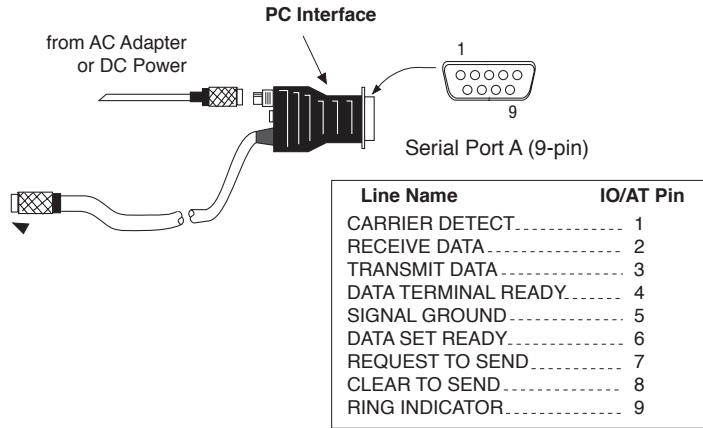

Proper External Antenna Installation - Signal Reception

The illustrations show both the proper and improper placement of a fixed antenna on a boat. Physical obstructions (buildings, large trees, mountains, etc.) will block satellite signals from reaching the receiver. If the unit is unable to get a position fix, move the receiver antenna so it has a clearer view of the sky, allowing it to choose from all of the satellites currently available.

For an illustration of the antenna mounting, see the mounting instruction sheet included with the antenna package.

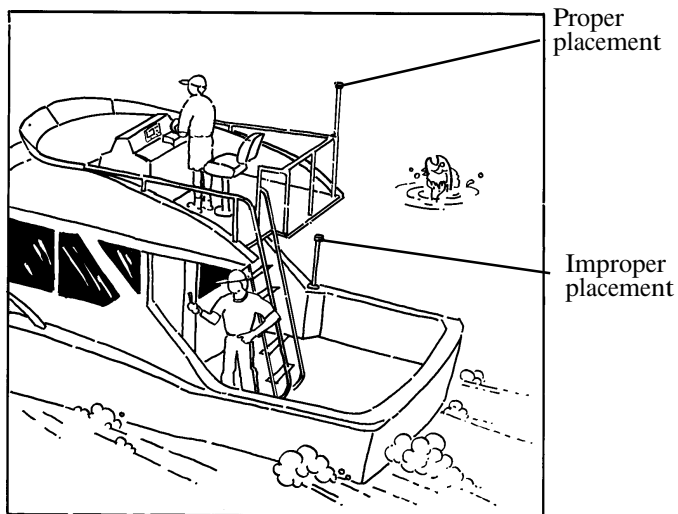

Navaid Icons

Plot Presentation symbols include the following new icons.



Areas, limits
Cargo transshipment area; Con-
tiguous zone; Continental shelf
area; Custom zone; Dumping
ground; Exclusive economic
zone; Fishery zone; Fishing
ground; Free port area; Harbour
area (administrative); Incinera-
tion area; Log pond; Military
practice area; National territo-
rial area; Restricted area; Sea
area; Sea-plane landing area;
Spoil ground; Straight territorial
sea baseline; Submarine translit
lane; Territorial sea area; no data
area.



Airport area
Airport area.



Anchorage area/Anchor



Anchor berth



Lattice

Beacon



Generic

Beacon, cardinal; Beacon, iso-
lated danger; Beacon, safe wa-
ter; Beacon, special purpose;
Beacon, generic



Tower



Withy



Bottom type
Seabed area.



Building, religious



Building, single



Barrel

Buoys



Can,
cylindrical

Buoys, cardinal; Buoy, in-
stallation; Buoy, isolated
danger; Buoy, internal;
Buoy, safe water; Buoy, spe-
cial purpose; Buoy, generic



Conical



Pillar



Spar, Spindle



Spherical



Super



Cairn



Cartographic objects
Closing line; Cartographic symbol; Cartographic line; Cartographic area; TEXT; Line, generic Text; Area, generic; National Character Set Text; Incomplete survey area.



Caution Areas



Cemetery



Chimney



Coastguard station



Compass



Compass, Distance
Local magnetic anomaly.



Composite objects
Airport; Anchorage; Channel edge; Deep water route; Defined water; Harbour; Range system; Lighthouse; Mooring trot; Navigation mark, afloat; Navigation mark, fixed; Traffic Separation Scheme System.



Control point



Crane



Cultural Dashed
Cable, overhead; Fence; Pipeline, overhead; Pylon; Telepheric, Tunnel entrance.



Cultural Features
Bridge; Built-up area; Railway; Road crossing; Road part; Runway; Sloping ground; Square.



Depths 1 (Shallow)
Depth area; Depth contour.



Depths 1 (Medium)
Depth area; Depth contour.



Depths 1 (Deep)
Depth area; Depth contour.



Depths 2
Dredged area; Spot Soundings; Shallow water blue.



Depths 3
Intertidal area; Zero meter contour.



Dish aerial



Extended navigational



Flagstaff/Flagpole



Flare stack



Fish haven



Fishing facility



Fog signal



Fortified structure



Lake



Landmarks
Tower.



Light



Light vessels



Light House



Marine farm/culture



Mast



Meta objects

Accuracy of data; Compilation scale of data; Horizontal datum of data; Nautical publication information; Production information; Sounding datum of data; Survey reliability; Survey source; Units of measurement of data; Vertical datum of data.



Mooring/Warping facility



Monument



Natural Features

Coastline; Dune; Hill; Lake shore; Land area; Land elevation; Land region; Salt Pan; Slope Topline; Tree; Vegetation area.



Natural Features (ICE)
Ice area; Pingo.



Natural Features (RIVERS)
Canal; Canal bank; Rapids;
River; River bank; Waterfall.



Navigational aid, generic



Navigational mark fixed



Navigational mark floating



Offshore Installation
Cable, submarine; Cable area;
Diffuser; Obstruction; Off-
shore production area; Pipe-
line, submarine/on land;
Pipeline area; Production in-
stallation.



Offshore platform



Pile



Ports

Berthing facility; Causeway; Checkpoint; Dam; Distance mark; Dock area; Dry dock; Dyke area; Dyke crown; Floating dock; Gate; Grid-iron; Harbour facility; Hulk; Landing place; Landing stairs; Lock basin; Oil barrier; Pontoon; Ramp; Shoreline construction; Slipway; Weir; Small craft facility.



Production Objects
Correction marker.



Radar dome



Radar, Radio
Radar, Radio, Electronic Positioning System
Radar station; Radar transponder; Radio station_refco.



Radar Reflector



Rescue station



Rocks
Underwater rock.



Sand waves



Services
Pilot boarding place.



Signals
Chain/Wire; Top mark.



Signal Station
Signal station, traffic; Signal station, warning.



Silo



Spring



Tank



Tracks, Routes

Deep water route part; Deep water route centreline; Fairway; Ferry route; Navigation line; Precautionary area; radar line; Radar range; Radio calling-in point; Recommended route centreline; Recommended track; Recommended traffic lane part; Traffic separation scheme crossing; Traffic separation scheme lane part; Traffic separation scheme round about; Traffic separation zone; Two-way route part.



Water Turbulence
Tideway; Water turbulence.



Weed/Kelp



Windmill



Windmotor



Wrecks

Listing of Available Datums

Datum	Full Name	Datum	Full Name	Datum	Full Name
WGS84	World Geodetic System	EUR79	European 1979	MONTJ	
NAD27	North American 1927	GANDA	Gandajika Base	NAHRW	Nahrwan, Saudi Arabia
NAD83	North American 1983	GEO49	Geodetic Datum 1949	OAHU	Oahu
ADIND	Adinda	GHANA		OEGYP	Old Egyptian
ALASK	Alaska	GRB36	Ordnance Survey of GB, 1936	OHAWA	Old Hawaiian
ARC50	Arc 1950	GUAM	Guam	OMAN	Oman
ARC60	Arc 1960	GUNSG	G. Segara	PITCA	Pitcairn Astro 1967
ASTRO	Camp Area Astro	GUNSR		QATAR	Qatar National
AUS66	Australian Geodetic 1966	HAWAI	Hawaii	QORNO	Qornoq
AUS84	Australian Geodetic 1984	HERAT	Herat North	RT90	Rt90 (Sweden)
BOGOT	Bogota Observatory	HJORS	Hjorsey 1955	SAM56	Provisional So. Am. 1956
BUKIT	Bukit Rimpah	HUTZU	Hu-tzu-shan	SAM69	South American 1969
CAMPO	Campo Inchauspe	INDIA	Indian (India, Nepal)	SCHWA	Schwarzeck
CANAD	Canada	IRAN	Iran	SICIL	Sicily
CAPE	Cape	IRELA	Ireland 1965	SIERR	
CARTH	Carthage	KAUAI	Kauai	SWISS	
CENAM	Central America	KERTA	Kertau 1948	TANAN	Tananarive Observatory 1925
CHATH	Chatham 1971	KKJ	KKJ (Finland)	THAI	Indian (Thailand, Vietnam)
CHUAA	Chau Astro	LIBER	Liberia 1964	TIMBA	Timbalai
CORRE	Corrego Alegre	LUZON	Luzon	TOKYO	Tokyo
CYPRU	Cyprus	MASSA	Massawa	VOIRO	
DJAKA	Djakarta (Batavia)	MAUI	Maui	WGS72	World Geodetic System 1972
EGYPT	Egypt	MERCH	Merchich	YACAR	Yacare
EUROP	European 1950 (All of Europe)	MINNA	Minna	ZANDE	Zanderij
EUR50	European 1950 (W. Europe)				

NMEA Messages

Your GPS receiver can be set to output GPS data in the NMEA 0183 version 1.5 or version 2.1 format to interface with other marine devices or equipment.

NMEA DATA MESSAGES. NMEA data is output at 4800 baud, 8, N, 1. These settings are acceptable to most equipment and software applications. The baud rate can also be set to 1200, 9600 or 19200.

There are several NMEA output message sets, each with a slightly different application. Check documentation for your external equipment to choose the appropriate message set.

SET OUTPUT/USAGE

V1.5.APA	BWC, APA, GLL, VTG Remote displays, version 1.5 marine autopilots
V1.5 XTE	XTE, BWC, GLL, VTG Version 1.5 Marine autopilots
V2.1 GSA	GSA, GSV, GLL, GGA, RMB, RMC, APB, and autopilots. Vers. 2.1 NMEA recommended navigation data, satellite data and autopilots.

NMEA Message Definitions

APA	Autopilot cross track error, direction to steer, status of GPS, route status, destination waypoint name, and bearing from origin to destination (old format).
APB	Revised autopilot message contains all of the above plus: heading to steer toward destination, bearing from the present position to the destination (magnetic or true).
BWC	Range and bearing to a waypoint
GGA	GPS position, time, fix quality, number of satellites used, HDOP (Horizontal Dilution of Precision), differential reference information, and age.
GLL	GPS-derived latitude, longitude, and time of fix.
GSA	GPS receiver operating mode, satellites used in the navigation solution reported by the \$--GGA sentence and DOP (Dilution of Precision) values.
GSV	Number of satellites in view, satellite numbers, elevation, azimuth, and SNR value.
RMB	Data status, cross track error, direction to steer, origin, destination waypoint, waypoint location, bearing to destination, and velocity toward the destination.
RMC	Time, latitude, longitude, speed, heading, and date.
VTG	Track (magnetic and true) and groundspeed (knots and KPH).

NMEA OUTPUT DATA FORMAT - VERSION 1.5

APA Autopilot Format A

1 2 3 4 5 6 7 8 9 10
APA,A,A,X.XX,L,N,A,A,XXX.,M,CCC

1 OR'ed Blink and SNR (A = valid, V = invalid)
2 Cycle Lock (A = valid, V = invalid)
3-5 Cross Track, Sense (L = steer left, R = steer Right), N.Mi. Units
6-7 Arrival Circle, Arrival Perpendicular (crossing of the line which is perpendicular to the course line and which passes through the destination waypoint.
8-9 Bearing dest. WPT. from origin WPT., Magnetic
10 Dest WPT. identifier

BWC To Selected Waypoint, Great Circle

1 2 3 4 5 6 7 8 9 10 11 12
BWC,XXXXXX,XXXX.XX,N,XXXXX.XX,W,XXX.,T,XXX.,M,XXX.X,N,CCCC

1 UTC of Bearing
2-3 Lat, N or S of waypoint
4-5 Long, E or W of waypoint
6-7 Bearing, True

8-9 Bearing, Magnetic
10-11 Distance, naut. miles
12 Waypoint identifier

GLL Geographic Position — Latitude/Longitude

1 2 3 4 5 6
GLL,1111.11,a,YYYYY.YY,a,hmmss.ss,A*hh

1-2 Latitude, N/S
2-3 Longitude, E/W
4 UTC of position
6 Status A = Data valid

VTG Actual Track and Ground Speed (SPD)

1 2 3 4 5 6 7 8
VTG,XXX.,T,XXX.,M,XX.X,N,XX.X,K

1-2 Track degrees, True
3-4 Track degrees, Magnetic
5-6 Speed, knots
7-8 Speed, kilometers/hour

XTE Cross Track Error

1 2 3 4 5
XTE, A,A,X.XX, L,N

1 Or'ed value Blink and SNR (A=Valid, V=Invalid)

- 2 Cycle Lock, (A=Valid, V=Invalid)
- 3 Cross Track Error
- 4 Steer Left of Right (L = Left, R = Right)
- 5 Units (N.Mi.)

- 7 Status: A = perpendicular passed at waypoint
- 8-9 Bearing origin to destination, M/T
- 10 Destination waypoint ID
- 11-12 Bearing, present position to destination, Magnetic or True
- 13-14 Heading to steer to destination waypoint, Magnetic or True

NMEA 0183 VERSION 2.1

APB Autopilot Sentence "B"

```

1 2 3 4 5 6 7 8 9 10 11 12 13 14
APB,A,A,x.x,a,N,A,A,x.x,a,c-c,x.x,a,x.x,a*hh

1 Status: A = Data valid

      V = Loran-C Blink or SNR warning
      V = general warning flag for other
      navigation systems when a
      reliable fix is not available.

2 Status: V = Loran-C cycle lock warning flag
      A = OK or not used

3 Magnitude of XTE

4 Direction to steer (L, R)

5 XTE units, nautical miles

6 Status: A = arrival circle entered

```

GGA Global Positioning System Fix Data

```

1 2 3 4 5 6 7 8 9 10 11
GGA, hhhmss.ss,1111.11,a,yyyyy.yy,a,x,xx,x.x,x.x,M,x.x,
12 13 14
M,x.x,xxxx*hh

1 UTC of Position

2-3 Latitude - N/S

4-5 Longitude - E/W

6 GPS Quality Indicator
0 = fix not available or invalid
1 = GPS SPS Mode, Fix valid
2 = Differential GPS, SPS Mode, fix valid
3 = GPS PPS Mode, fix valid

7 Number of satellites in use (00-12, may be

```

different from the number in view)

- 8 Horizontal dilution of precision
- 9 Antenna altitude above/below mean sea level
- 10 Units of antenna altitude, meters
- 11 Geoidal separation - difference between the WGS-84 earth ellipsoid and mean sea level (geoid), "-" = mean sea level below ellipsoid
- 12 Units of geoidal separation, meters.
- 13 Age of Differential GPS data - Time in seconds since last SC104 Type 1 or 9 update, null field when DGPS is not used
- 14 Differential reference station ID, 0000-1023

GLL Geographic Position — Latitude/Longitude

1 2 3 4 5 6
GLL,1111.11,a,yyyy.yy,a,hmmss.ss,A*hh

- 1-2 Latitude, N/S
- 2-3 Longitude, E/W
- 4 UTC of position
- 6 Status A = Data valid
V = Data not valid

GSA GPS DOP and Active Satellites

GPS receiver operating mode, satellites used in the navigation solution reported by the \$--GGA sentence, and DOP values.

1 2 3 4 5 6 7
GSA,a,x,xx,xx,xx,xx,xx,xx,xx,xx,xx,xx,xx,x.x,x.x,x.x*hh<CR><LF>,
1 Mode: M=Manual, forced to operate in 2D or 3D mode, A=Automatic, allowed to automatically switch 2D/3D
2 Mode: 1= Fix not available, 2=2D, 3=3D
3-4 PRN numbers of satellites used in solution (null for unused fields)
5 PDOP
6 HDOP
7 VDOP

GSV GPS Satellites in View

Number of satellites (SV) in view, PRN numbers, elevation, azimuth and SNR value. Four satellites maximum per transmission, additional satellite data sent in second or their message. Total number of messages being transmitted and the number of messages being transmitted is indicated in the first two fields.

```

1 2 3 4 5 6 7 8 9 10 11
GSV,x,x,xx,xx,xx,xxx,xx.....xx,xx,xxx,xx*hh<CR><LF>

```

- 1 Total number of messages, 1 to 3
- 2 Message number, 1 to 3
- 3 Total number of satellites in view
- 4 Satellite PRN number
- 5 Elevation, degrees, 90° maximum
- 6 Azimuth, degrees True, 000 to 359
- 7 SNR (C/No) 00-99 dB, null when not tracking
- 8-9 2nd-3rd SV
- 10-11 4th SV

Notes: 1) Satellite information may require the transmission of multiple messages. The first field specifies the total number of messages, minimum value 1. The second field identifies the order of this message (message number), minimum value 1.

2) A variable number of "PRN-Elevation-Azimuth-SNR" sets are allowed up to a maximum of four sets per message. Null fields are not required for unused sets when less than four sets are transmitted.

RMB Generic Navigation Information (immediately follows RMC)

```

1 2 3 4 5 6 7 8 9 10 11 12 13 14
RMB,A,X.XX,a,c--c,c--c,1111.11,a,yyyyy.yy,a,x.x,x.x,x.x,A *hh

```

- 1 Data Status (A = valid, V = invalid)
- 2-3 XTE, naut. miles and direction to steer (L or R) [If XTE exceeds 9.99 NM, display 9.99 in field 2.]
- 4 Origin waypoint ID
- 5 Destination waypoint ID
- 6-7 Destination Waypoint Latitude (N or S)
- 8-9 Destination Waypoint Longitude (E or W)
- 10 Range naut. miles, present fix to destination waypoint Great Circle. [If range exceeds 999.9 nm, display 999.9.]
- 11 Bearing, True, Great Circle, Present fix to dest. waypoint
- 12 Closing velocity to destination, knots
- 13 Arrival (OR'ed arrival circle and crossing of line which is perpendicular to the course line and which passes through the destination waypoint.)
- 14 CHECKSUM (Mandatory in this sentence.)

RMC Transit Specific (to be followed by RMB)

1 2 3 4 5 6 7 8 9 10
RMC, hhmmss.ss,A,1111.11,a,yyyy.yy,a,x.x,x.x,xxxxxx,x.x,a *hh

- 1 Time, UTC of position fix
- 2 Status (A = valid, V = Navigation receiver warning)
- 3-4 Latitude at UTC time, N or S
- 5-6 Longitude at UTC time, E or W
- 7 Speed over ground, knots
- 8 Course over ground, degrees
- 9 Date (DDMMYY)
- 10 Magnetic variation, degrees
- 11 Magnetic variation, sense (E or W)
- 12 CHECKSUM (Mandatory in this sentence)

The formats listed are NMEA formats and Magellan receivers may not output all of the information listed for a particular format.

A complete copy of the NMEA specifications can be obtained from:

NMEA
P.O. Box 3435
New Bern, NC 28564-3435
(919) 638-2626

Abbreviations

2D	Two-dimensional	GPS	Global Positioning System
3D	Three-dimensional	HDOP	Horizontal Dilution of Precision or Geometric quality
BRG	Bearing	INIT	Initialize position
CDI	Course Deviation Indicator	Km	Kilometers
CLR	CLEAR	Kph	Kilometers per hour
COG	Course over ground	KH	Kilometers per hour
MAP/CTR	Map/Center key	Kts	Knots
CTS	Course to steer	KT	Knots
DEG	Degrees		
DST	Distance to go		
ENT	ENTER		
EPE	Estimated position error		
ETA	Estimated time of arrival		
FM	Fathoms		
Ft	Feet		

LAT	Latitude	SOG	Speed over ground
LON	Longitude	SPD	Speed
MH	Miles per hour	STR	Direction to steer (so that COG equals CTS)
Mi	Miles	TDs	Loran-based coordinate system
MIN	Minute	TRKPLT	Track plot mode
mm	Minutes (decimal format to two degrees of resolution)	TRN	Direction to turn (so that COG equals BRG)
mmm	Minutes (decimal format to three degrees of resolution)	TTG	Time To Go
Mph	Miles per hour	UTM	Universal Transverse Mercator
M	Meters	UT	Universal Time (Greenwich Mean Time)
NAV	Navigate	VMG	Velocity made good
Nm	Nautical mile	WPT	Receiver-generated waypoint name
NXT PG	Next screen	XTE	Cross track error
OSGB	Coordinate system used in Great Britain		
POS	Receiver-generated name for current position		
POWER	Power Key		
SA	Selective Availability		
SEC	Seconds		
SET REF	Set reference		

Specifications

Size	3.25" x 7.5" x 1.70" (8.3 cm x 19.1 cm x 4.3 cm)
LCD display dimensions	4" diagonal
Temperature:	
Operating	14°F to 140°F (-10°C to 60°C)
Storage	-40°F to 167°F (-40°C to 75°C)
Case	splashproof
Antenna	Built-in low-profile patch

Operating Characteristics

Accuracy:	
Position	12 meters RMS in 3D operation without SA
Velocity	0.5 meters/second RMS
Speed limit	up to 951 MPH (1,530 kilometers per hour)

Time to First Fix:

Cold start*	less than 1 minute
Warm start*	30 seconds

* Warm start: the receiver has obtained a position fix within the last 2 hours. Cold start: the receiver has been idle for 2 hours or longer but has initial position and time.

Storage capacity	up to 500 waypoints, up to twenty-five 30-leg routes
Update rate	once every second
Input voltage	9 - 32 VDC
Power consumption	1 watt
Data Input/Output	

Differential Input Baud Rate: 1200, 4800, 9600, 19200

NMEA Input/Output Baud Rate: 1200, 4800, 9600, 19200

Coordinate Systems

Positions are locations that are described in a unique way so that one location cannot be confused with another. This is done by using a coordinate system to describe locations. Your Magellan receiver has the ability to use any one of ten different coordinates systems; LAT/LON (latitude and longitude), UTM (Universal Transverse Mercator), TD, OSGB, Irish Grid, German Grid, French Grid, Finnish Grid, Swedish Grid, or Swiss Grid. The one you select (in SETUP) will be determined by the maps and charts you use; you would generally want the receiver to display position coordinates in the same system that is used by your maps.

LAT/LON Coordinate System. LAT/LON is the most commonly used coordinate system today. It projects lines of latitude (parallels) and lines of longitude (meridians) onto the earth's surface. Lines of latitude are the equator and the horizontal lines that are parallel to it. Lines of longitude are the vertical lines that are perpendicular to the equator and pass through the poles. A position is described as being the intersection of a line of latitude and a line of longitude.

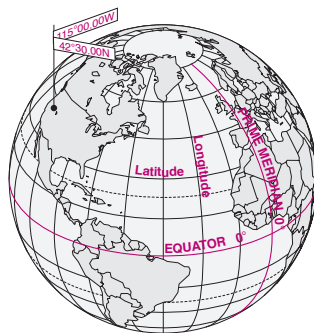

Specifically, a position is up to 90 degrees north or south of the equator (up to the poles, which are 90°N and 90°S; the equator is 0° latitude), and up to 180 degrees east or west of the Prime Meridian, which is 0° longitude. (The Prime Meridian passes through Greenwich, England.) Parts of a degree are minutes; there are 60 minutes (written as 60') to a degree. Minutes can also be divided into smaller units. Fractions of a minute can be expressed as decimals or as seconds. (There are 60 seconds to one minute, written as 60"). So a Lat/Lon position coordinate can be expressed in two ways, which your Magellan GPS receiver displays as 25°47.50 or 25°47'30.

UTM Coordinate System. Another commonly used coordinate system is UTM (Universal Transverse Mercator), which is generally found on land-based maps and quad sheets that are produced by government map providers. On land, you may find that UTM coordinates are easier to use than Lat/Lon.

Instead of projecting an imaginary grid of intersecting lines onto the globe, UTM projects sections of the globe onto a flat surface. Each of these sections is called a "zone." There are 60 zones to cover the entire earth between 84°N and 80°S (polar areas are not described by UTM). Each zone is 6° wide as projected from the earth's center.

A UTM position is described by three elements; the zone it is in, the easting, and the northing. Eastings and northings measure how far into a zone a position is in meters. Eastings are an east/west measurement, and correspond roughly to longitude. Northings are a north/south measurement, and correspond to latitude.

This chart shows the position of Magellan Systems described in both Lat/Lon and UTM coordinates.

LAT/LON		UTM
DEG/MIN	DEG/MIN/SEC	
34°06.58N	34°06'35"N	11 4 23 818 E
117°49.56W	117°49'34"W	37 74 624 N

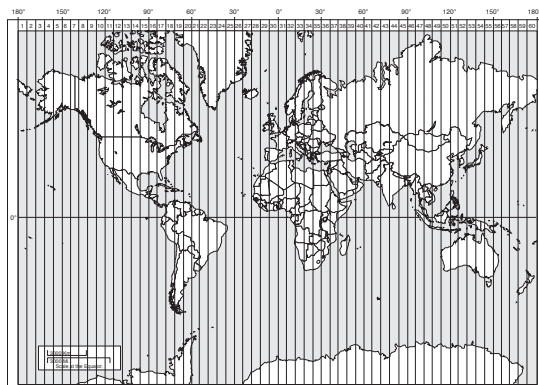

NOTE: The area described by the UTM coordinate system extends to 84°N and to 80°S.

Other Coordinate Systems. OSGB coordinates are similar to UTM's, but they describe only Great Britain. They must be used with the GBR36 datum, which also describes Great Britain. This coordinate system cannot be used in any other part of the world. The NAV 6000 automatically selects the GBR36 datum when the OSGB coordinate system is selected in Setup. (While OSGB coordinates must be used with the GBR36 datum, the GBR36 datum can be used with LAT/LON coordinates; just be sure the map you are using uses both LAT/LON and GBR36.)

 If you select OSGB in the COORD SYS portion of the Setup Menu be sure to change the map datum back to the one you will be using (WGS84 is the default) when changing to another coordinate system.

Irish Grid uses the Ireland datum, Swedish Grid uses the RT90 datum, Swiss Grid uses the Swiss datum, French Grid uses the French datum, German Grid uses the German datum.

What Is GPS?

GPS is a constellation of navigation satellites that orbit the earth. The precise time and position information transmitted by these satellites is used by a GPS receiver to triangulate a position fix.

The system is now officially declared “initial operational,” and provides continuous, 24-hour 3D (position plus elevation) coverage anywhere on the earth.

GPS was developed by the United States Department of Defense to provide consistent, reliable navigation information that is unaffected by rough terrain and bad weather, and is highly resistant to multipath errors and interference. The DoD continues to administer and control the Global Positioning System.

Although GPS was developed as a military navigation system, its civilian and commercial uses were recognized. The satellites therefore transmit two codes, a military-only encrypted code (PPS) and a civilian-access, Standard Positioning Service (SPS) code. All commercial and consumer GPS receivers are SPS receivers.

How Does GPS Work?

Each GPS satellite transmits its precise location (position and elevation) and the start time of the transmission. A GPS receiver acquires the signal, then measures the interval between transmission and receipt of the signal to determine the dis-

tance between the receiver and the satellite: this is ranging. Once the receiver has computed range for at least three satellites, its location on the surface of the earth can be determined.

Each satellite transmits two types of data, almanac and ephemeris. Almanac data is general information on the location and health of each satellite in the constellation. Since it contains general information, an almanac can be collected from any satellite. A receiver with a current almanac in its memory knows where in the sky to look for satellites, given its last known position and the time of day. Ephemeris data is the precise satellite positioning information that is used for ranging. Each satellite transmits its own ephemeris data.

Both almanac and ephemeris data are required for a GPS receiver to locate and acquire satellites quickly and compute a position fix.

Accuracy

GPS positioning with an SPS receiver that is intended for general use will produce accuracies of 25 meters or better.

In fact, SPS receivers have proven to be far more accurate than anyone anticipated. DoD has decided that 25-meter ac-

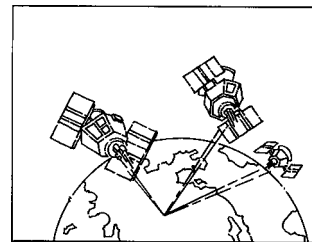

curacy is a potential risk, and has introduced Selective Availability (SA) to maintain a military advantage. SA is a random error that is introduced to the SPS code ephemeris data and reduces the accuracy of any SPS receiver. The size of the error changes, but rarely exceeds 100 meters.

The DoD civil GPS user policy is that GPS accuracy as affected by SA is sufficient for general navigation. In an open environment, it usually is. Even with SA, a GPS receiver will bring you within visual range of a destination or target, and GPS remains the best available source of accurate, repeatable navigation and positioning information.

If you feel that you really need 25-meter accuracy, the effects of SA can be overcome with a technique called broadcast differential to produce highly accurate position fixes.

DGPS

Differential GPS (DGPS) computes the size of the error and applies it to positioning information. There are several ways to perform DGPS, one of which is broadcast differential. Broadcast differential uses GPS receivers at control sites to measure the range errors for all visible satellites and determines a correction for each satellite. These corrections are broadcast in the RTCM SC-104 format by a radio beacon at the control site to any differential beacon receiver that is within range of the signal.

The differential beacon receiver receives and demodulates the signal, then relays it to the user's differential-ready GPS re-

ceiver. The user's GPS receiver applies the corrections to the positioning information it collects to compute differentially corrected position and navigation data.

This technique requires that your GPS receiver be connected to a compatible differential beacon receiver (such as the Magellan DBR™, which is compatible with all differential-ready Magellan receivers). You must also be within range of a differential radio beacon.

More Information

For information relating to the operation of your Magellan GPS receiver, call Magellan at (909) 394-5000 and ask for Customer Service.

General information on the Global Positioning System and satellite status is available from the Civil GPS Information Center (GPSIC) in Virginia. It is operated by the United States Coast Guard for the Department of Transportation, and was established to provide information and to serve as a point of contact. There are three ways to telephone the GPSIC:

1. 24-hour recorded message at 703-313-5905
2. Website at www.navcen.uscg.mil
3. 24-hour live operator at 703-313-5900

Navtech provides seminars (for a fee) and books on GPS and navigation. The Navtech bookstore can be reached at 800-NAV-0885 or 703-931-0500, or at FAX 703-931-0503.

Explanation of Data Terms

BRG. Bearing is the direction of a point (waypoint or cursor position) in relation to the boat or another point., as measured in degrees from north in a clockwise direction. The receiver uses either true north or magnetic north, as selected in the Setup Menu. The illustration shows a simple compass rose with the eight cardinal directions noted with their bearing.

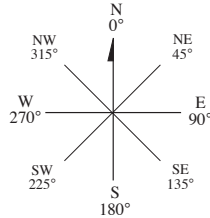

COG. Course over Ground is the direction of movement expressed as bearing. If a boat is pointing exactly north (0°) and there are no other factors affecting its travel, the COG would be 0° but that is rarely the case. Water currents and wind can affect the course the boat is taking. If there is a current passing from left to right across the boat (90°) the COG would change even though the bow of the boat is still pointing north. COG is measured in degrees with North being 0° .

CTS. Course to Steer. The optimum direction the boat should be steered in order to efficiently make headway back to the courseline while also proceeding toward the destination waypoint. It is a "compromise" course bearing that projects from your current position to a point (B1) on the courseline mid-way between a point (B2) perpendicular to your position and the current destination waypoint (B).

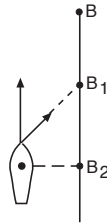

DST. Distance to go to an active waypoint, or the distance between two waypoints in a route leg.

SOA. Understanding speed of advance is a little tricky but once you do it becomes fairly simple. For this example we will use an exaggerated sample so as to clearly describe SOA.

The boat is heading towards the destination waypoint and is currently at point A. If the boat had followed the original course (A_1 – destination), it would be somewhere on the line A_1 — B_1 . (The XTE for this sample is the distance between points A and A_1 .) In 1 hour the boat is at point B and has travelled 34 NM (equivalent to a speed of 34 knots).

Now if you project downwards to the course the boat should be on, you arrive at point B_1 .

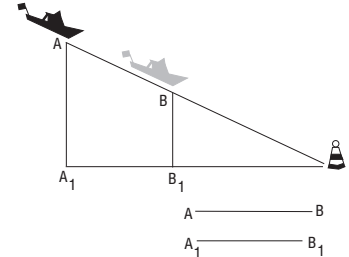

Comparing the lines from points A and B and from points A_1 and B_1 you see that while the person travelled 34 NM he moved only 30 NM along the courseline. If he moves 30 NM on the courseline in 1 hour, his SOA is 30 knots, whereas SOG would be 34 knots.

SOG. (Speed Over Ground) This is the speed at which the vehicle/vessel is moving in respect to the earth. SOG is measured in knots, miles per hour, or kilometers per hour. (This is not the same as speed through water, if you are travelling by boat.)

STR. Steering. The difference between COG and CTS. If COG is 25° and CTS is 30° , then STR is 5° Right.

TTG. Estimated time en route to reach the active waypoint.

TRN. Turning is the difference between COG and BRG. If COG is 80° and BRG is 75° , TRN is 5° left.

VMG. Velocity made good is the component of the velocity that is in the direction of the destination. In the above example, the boat is travelling directly towards the destination even though not on the coursesline originally set. In this case, all of this velocity is being applied towards arriving at the destination, (i.e., $VMG = SOG$). Should the boat veer away from this course and travel in a line parallel to the original coursesline ($A_1;B_1$) it would be travelling on a course that would not intercept the destination waypoint. As the boat moved along, less and less of its velocity would be applied toward arriving at the destination. By the time point D is reached, none of the velocity is applied to getting closer to the destination and the VMG would be 0. As it moves to point E, it is moving away from the destination and its VMG is a negative value.

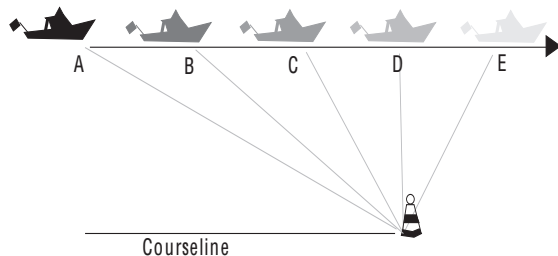

XTE. XTE (cross track error) is the perpendicular distance from your boat to the coursesline that you are travelling. As you will see in the discussion of other data items, XTE is important in computing them accurately. Keeping XTE at a minimum will help maintain the most direct route to your destination. This illustration shows a boat coursesline. The arrows between the boat and the coursesline is the distance of XTE and this boat is to the left of the coursesline. This boater would need to steer right to close the XTE.

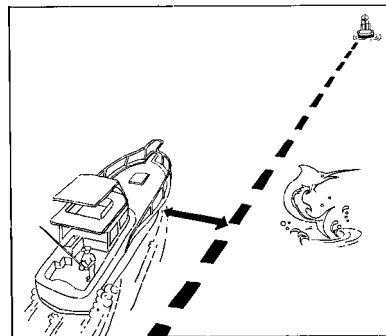

Glossary

Active Leg	The segment of a route currently being travelled.	Datum	Refers to the theoretical mathematical model of the earth's sea level surface. Map makers may use a different model to chart their maps from so positions will differ from one datum to another. The datum for the map you are using can be found in the legend of the map.
Azimuth	The angular measurement from the horizon to a satellite or other object.	EPE	Estimated Position Error is the approximate error (between 0 and X) introduced in the ephemeris by the U.S. Department of Defense for reasons of security. This random error, known as Selective Availability (SA) is not due to receiver error and is not significant enough to affect navigation for most purposes (See DGPS in appendix).
Bearing	The compass direction from your position to a destination, measured to the nearest degree.	Geometric Quality	Measures the probable accuracy of a position fix, based on the position of the satellites relative to each other.
Coordinates	A unique numeric or alphanumeric description of position.	GOTO	A single leg route with the present position being the start of the route and a defined waypoint as the destination.
Course	The direction in degrees from the start waypoint of a course line to its destination.		
CTS	The optimum direction the vessel should be steered in order to efficiently make headway back to the courseline while also proceeding toward the destination waypoint. It is a "compromise" course bearing that projects from your current position to a point on the courseline mid-way between a point perpendicular to your position and the current leg destination waypoint.		

Heading	The direction in which the NAV 6000 is moving, track or ground course, (due to wind, current, and so forth), and may also be different from the course.	Longitude	The angular distance east or west of the prime meridian (Greenwich meridian) as measured by lines perpendicular to the parallels and converging at the poles from 0° to 180°.
Latitude	The angular distance north or south of the equator measured by lines encircling the earth parallel to the equator in degrees from 0° to 90°.	Magnetic North	The direction toward the north magnetic pole from the observer's position.
LAT/LON	Coordinate system using latitude and longitude coordinates to define a position on the earth.	OSGB	A coordinate system describing only Great Britain, similar to UTM's. Generally used with GBR36 datum, which also describes only Great Britain. This coordinate system cannot be used in any other part of the world. The NAV 6000 automatically selects the GBR36 datum when the OSGB coordinate system is selected in Setup. (While OSGB coordinates must be used with the GBR36 datum, the GBR36 datum can be used with LAT/LON coordinates; just be sure the map you are using uses both LAT/LON and GBR36.)
Leg (Route)	A segment of a route that has a starting (FROM) waypoint and a destination (TO) waypoint. A route may consist of 1 or more legs. For a route that is from waypoint A to waypoint B, waypoint B to waypoint C, and waypoint point C to waypoint D has three legs with the first leg being from waypoint A to waypoint B.	Position Fix	Position coordinates as computed by the NAV 6000.

Reverse Route	Duplicates an existing route but in reverse order.	True North	The direction to the geographical North Pole from an observer's position. The north direction on any geographical meridian.
Route	A planned course of travel that is defined by a sequence of waypoints. When active, the route is used in the calculation of all navigation data except position, speed over ground and track/course over ground.	Track	The actual path travelled, which may differ from the planned course.
Start and Destination Waypoint (FROM/TO)	Waypoints that mark the beginning and ending of a leg of a route.	Track History	The track over a selected length of time.
TDs	Coordinate system using lines of position determined by the Loran-C signals. Many coastal navigators use TDs because Loran is a familiar radio aid navigation and TDs are clearly marked on their charts. Your Magellan receiver can display position coordinates in TDs by converting from LAT/LON.	UT	Universal Time, formerly referred to as Greenwich Mean Time (GMT).
Time To Go	The estimated time for the receiver to reach the destination from its current position based on the current VMG.	UTM	Universal Transverse Mercator (UTM) metric grid system used on most large and intermediate scale land topographic charts and maps.
		VMG	Velocity Made Good. The component of the velocity that is in the direction of the destination.
		Waypoint	A location saved in the unit's memory which is obtained by entering data, editing data, calculating data or saving a current position. Used to create routes

INDEX

Abbreviations 84
Accuracy 89
Alarms 50; arrival radius 50; anchor alarm 50; XTE alarm 51
Antenna installation 71
Appendix 63
Attributes, viewing Waypoint and Navaid attributes 23
Backlighting 6, 16
Backtrack 44; activate 44, deactivate 44
Batteries 64
Baud rate 49
Beeper on/off 50
Cancelling an operation 16
C-card Installation 65, 66
CDI - Course Deviation Indicator 25, 26
Chart settings 53
Contrast 6, 16, 45
Coordinate System 46, 87
Customizing the NAV 1 screen 25, NAV 2 screen 26
Data input 16
Data terms 91
Date format 46
Datums 47, 77

Distance, Units 48, finding distance and bearing on map 25
DGPS 90
Depth units 48
Electrical connections 69
Elevation mode 47
Getting started 3
Glossary 93
*GOTO 33; creating 33, from Nearest 34, by Waypoint name
33, to cursor position 35, deleting 35*
Icons 72
Initialization 6
Installation instructions 64
Introduction 1
Land settings 51
Language Selection 4
Lat/Lon 85
Leg (see Routes)
Light 6
Map configuration/settings 51
Map Datum 47
Map Orientation 21, 53
Map scale 20
Map screen 19
Map Setup 51

Map shift 54
Marine settings 52
Memory reset 58
Menu functions 45
MOB 35
Navaid icons 72
Navaid settings 52
Navigation NAV1 screen 25; NAV2 screen 26
NMEA 49, 69, 78
North Reference 48
ON/OFF 5, 15
Packing list 1
PC cable connection (optional) 70
Plotter mode 22
Port Setup functions 49
Power on/off 5, 15
Projected course 54
Reference 15
Root screens 16
Routes 33, 36; activating 37; activating a leg 42; appending a waypoint 41; copying a route 43; creating 36; deactivating 37; deleting 43; editing 38; inserting a waypoint in a route 38, 39; moving a waypoint in a route 41; removing a waypoint 40; replacing a waypoint in a route 42; reversing 38; route list 33.
Sat Status 17
Setup 45
Signal reception 71
Simulator 58
Specifications 86
Speed Units 48
Sunrise/sunset and lunar information 57
System setup 45
Time reference, format 45
Track History /Plotting 55, 56; clearing 56
Trip planning 56
Troubleshooting 60
Tutorial 9
Warning messages 62
Waypoints 28, creating 28 ; deleting 31; deleting all 32; editing 31; finding 30; modifying waypoint data fields 29; moving a waypoint 32; nearest 32; saving the current position as a waypoint 29; saving the cursor position as a waypoint 28; viewing 30
What is GPS? 89



960 Overland Court, San Dimas, CA 91773 USA (909) 394-5000

22-10311-001